

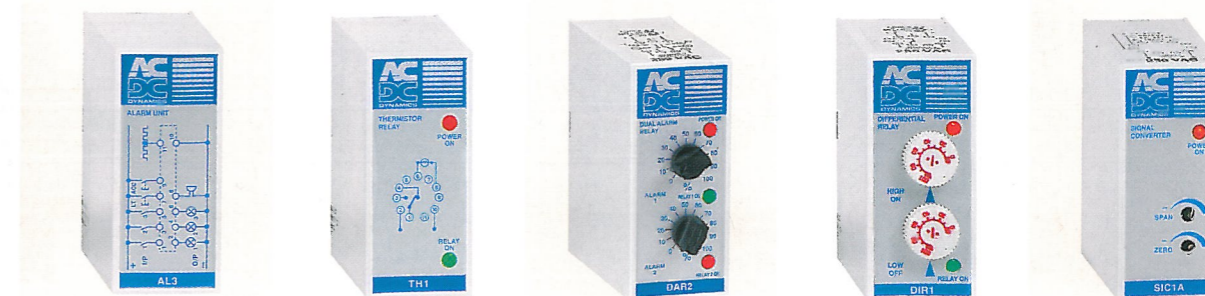



**TIMERS**

**PROCESS CONTROLS**



Type	Code	Outputs	Mode of Operation
Star-Delta Timer	SDP1	SPDT	When supply voltage is applied connection between 1 and PIN 4 is made. The time period starts for Star connection. After the Star set time has elapsed connection between pin 1 & 4 is opened and stays in a neutral position for 100mS. After the 100mS pause connection is made between pin 1 & 3 for the Delta contactor.
One-shot Timer	OSP1, OSP2	SPDT, DPDT	LINK:5-6: Pulse on energisation LINK 6-7: Pulse on de-energisation. When the power is applied the relay operates for 0.5 sec. When power is de-energised the relay operates for 0.5 sec.
Triac Flasher	TFP1, TFP2	Triac output	<b>TFP1 (230VAC only)</b> Upon applying the supply the lamp will flash with an equal on and off time until the supply is removed. This on and off time is adjustable from 0.02 - 1 sec. <b>TFP2 (230VAC only)</b> Upon applying the supply, lamp 1 will switch on then switch off and then lamp 2 will switch on. This on and off time is adjustable from 0.02 - 1 sec. <b>Triac:</b> 1000W (4A) @ 250VAC
Relay Flasher	RFP1, RFP1/A	SPDT	<b>RFP1</b> On applying the supply, the lamp will flash with a fixed equal on and off time. This will continue until the supply is removed. Can be used to switch one lamp or two alternating lamp circuits. <b>RFP1/A</b> As per RFP1 except that the equal on and off time is adjustable from 0.02 to 3 sec.
Defrost Timer	DET1, DET1/F	WITHOUT FAN DELAY, WITH FAN DELAY	Upon application of supply voltage, cooling cycle starts, (4, 6, 8 or 12 hrs) followed by defrost cycle (1-60min). LINK 5-6: As above except defrost cycle starts first. <b>DET1/F:</b> Is for freezer rooms and has additional relay for fan delay (6-360 Sec). LEDs "defrost on" "fan on". Dip switch selection: cycle times <input type="checkbox"/> 14 hour <input type="checkbox"/> 16 hour <input type="checkbox"/> 18 hour <input type="checkbox"/> 12 hour
Repeating Pulse	RP1	SPDT	Upon application of the supply voltage, the delay period begins. On expiry of the set time, the relay pulses on 0.5 sec and a new time period begins. This repeating continues until supply voltage is disconnected.

Code	Outputs	Mode of Operation
Alarm 3/P	AL3	4 x SPST
Relay 30/P	TH1	SPDT
Thermistor Relay	TH1	SPDT
Single & Dual Alarm Relay	SAR1, DAR2	SPDT, DPDT
Differential Relay	DIR, DIRV	SPDT
Signal Converter	SIC1†, SIC2†	4-20mA, 0-10V

**AL3:** On closing of any input contact, the corresponding output relay and hooter will energise. By using a common flasher connect to PIN 11 lamp 1 will flash. By pressing the accept button the lamp will steady and remain on until the fault is removed, and the hooter will stop. More alarms can be added by merely commoning up more modules with no restriction. Pins to be common when expanding; 11,10, 9, 7 and common of hooter.

**TH1:** *Failsafe design.* The relay is normally energised, when one of the thermistors reaches tripping temperature the relay de-energises. The relay will energise when the temperature drops to below trip level.  
**Latch facility** Link PINS 7-9. Relay remains de-energised after tripping. To reset, break supply voltage or operate N/C external reset device connected to PINS 7-9.

**SAR1: Single trip point**  
**DAR2: Two trip point** (2 relay outputs independently adjustable)  
The relay is normally de-energised and will energise when the input signal reaches the set level, set by a potentiometer. The relay will de-energise when the input signal drops below the set level by 3%.  
The second alarm relay operates the same but set at a different trip level.

**DIR, DIRV:** This module provides a relay output with high and low set points from an analogue instrument signal.  
The output relay will energise on the high set point and de-energise on the low setpoint offering a wide adjustable differential.  
When more than one unit is used in series and the supply is DC, an isolator must be used for each unit:  
**ISO-12VDC**  
**ISO-24VDC**

**SIC1†, SIC2†:** The Signal Converter modules convert various input signals to a 4-20mA or 0-10V DC signal. They are intended for use with all PLC and other instrumentation systems.  
**†Input selection**  
A: 0-5 Amps AC/DC  
B: 0-1 Amps AC/DC  
R: Ohms  
V: Voltage range AC/DC  
**Calibration:** For field calibration, energise module and set input to maximum. Adjust SPAN until output is 20mA/10V. Set input to minimum requirement and adjust ZERO until output is 4mA/0V. Calibration is complete.  
Red LED: Power on.

**Connection Diagram**

**Supply AC** Galvanic isolation with internal transformer 12, 24, 48, 110, 230, 400, 525VAC ±15% (Test volts 2kV)

**Supply DC** 12, 24, 48VDC

**Specification** Output rating: SPDT: 10A @ 250VAC  
DPDT: 5A @ 250VAC  
Triac: 1000W (4A) @ 250VAC  
Power consumption: AC 1.5VA  
DC 100mA @ 12VDC

**Connection Diagram**

**Specification**

- AL3:** Lamp test Pin 7, Alarm accept Pin 9, Hooter Pin 8. To be utilised with relay flasher RFP1 to Pin 11.
- TH1:** Tripping resistance 1.2kV. No. of thermistors to be connected in series not to exceed 1kV.
- SAR1, DAR2:** Input signal: 4 - 20mA, 0 - 20mA, 0 - 5VDC, 1 - 5VDC.
- DIR, DIRV:** Input signal: 4 - 20mA, 0 - 20mA, 0 - 5VDC, 1 - 5VDC.
- SIC1A, SIC2A:** Inputs: SIC\*A: 0-5 Amps, AC/DC; SIC\*B: 0-1 Amps, AC/DC; SIC\*R: 1-20kV; SIC\*V 10V: 0-10V, AC/DC; SIC\*V 150V: 0-150V, AC/DC; SIC\*V 300V: 0-300V, AC/DC; SIC\*V 600V: 0-600V, AC/DC. \* 1: for 4-20mA. 2: 0-10V output.

**Power Consumption** DC: 600mA @12VDC; AC ± 1.5VA

**Supply AC** Not Available; Galvanic isolation with internal transformer 12, 24, 48, 110, 230, 400, 525VAC ±15% (Test volts 2kV)

**Supply DC** 12, 24VDC; 12, 24, 48VDC

**Contact rating** SPDT: 10A @ 250VAC; DPDT: 5A @ 250VAC

AUTOMATION PRODUCTS

AUTOMATION PRODUCTS

**PROCESS CONTROLS**

**PROCESS CONTROLS**



Type	Namur Sensor Relay	Pivot Shut Down Relay	Signal Isolator (Transducer)		Signal Isolator Transmitter
Code	NS1	VCT1	Input	Output	Code: S4X-DT-* *Add Supply Voltage: A = 85 to 265VAC/100 to 330 VDC B = 20 to 60VDC
Outputs	SPDT	SPDT	4-20mA 0-10V 4-20mA 4-20mA	4-20mA 0-10V 10-0V	Multi-range Input and Output Selectable by DIP switches on side of unit.
Mode of Operation	<i>Failsafe design.</i> The Namur sensor relay converts the changing current of an Inductive or Capacitive Namur sensor into a relay switching. The sensor can be connected between 5 & 6 to energise the relay when the sensor is activated, or between 6 & 7 to energise the relay when the sensor is deactivated.  See page 210 for Namur sensors.	<i>Failsafe design.</i> For use with centre pivot irrigation systems to prevent overwatering of the field. On application of voltage, the output relay energises for the adjustable start up delay period. Once running, if the pivot arm motors do not draw a minimum adjustable current within an adjustable time (usually 3 minutes for 20% watering), the output contact de-energises, switching off the PUMP START circuit.	All outputs are galvanically isolated from inputs.  Output: 4-20mA into 0-600 ohms load.  Isolation between IP/OP and Mains = 600V		DC Input Range DC Output Range V1: 0 - 50mV V2: 0 - 5V V2: 0 - 5V V3: 1 - 5V V3: 1 - 5V V4: 0 - 10V V4: 0 - 10V A1: 0 - 1mA A1: 0 - 1mA A2: 0 - 10mA A3: 0 - 20mA A3: 0 - 20mA A4: 4 - 20mA A4: 4 - 20mA
Connection Diagram			<p><b>Potentiometer Transmitter</b> Code: S4X-PT-A Supply Voltage: AC 85 - 265V/DC 100 - 330V Input Potentiometer: (3 Wire) 1: Total resistance 100V - 10KV</p> <p><b>RTD (PT100) Transmitter (Isolator)</b> S4X-RR-P -A4- A B P: PT100 F: 0 to 100°C D: -50 to 200°C G: 0 to 200°C</p> <p>DC Output Multi-Range (Selectable by DIP Switch) V2: 0 - 5V A2: 0 - 10mA V3: 1 - 5V A3: 0 - 20mA V4: 0 - 10V A4: 4 - 20mA A1: 0 - 1mA</p> <p>Supply Voltage A = AC 85 to 265V DC 100 to 330V B = DC 20-60V</p> <p><b>Speed (Frequency Transmitter)</b> S4X-RT-B-2-M-A 0-100Hz Input S4X-RT-E-2-M-A 0-1KHz Input S4X-RT-F-2-M-A 0-2KHz Input S4X-RT-H-2-M-A 0-10KHz Input Supply Volts: 85 to 265VAC Output Programmable: 4-20mA, 0-10V</p>		
Specification	Sensor current: 8mA Open voltage: 8.5V	For use with DIN type CT-5 current transformer (see page 128) (Input 0-4V)			
Power consumption	AC: ±1.5VA DC: 100mA @ 12VDC		1.5VA		
Supply AC	Galvanic isolation with internal transformer 24, 48, 110, 230, 400, 525VAC ±15% (Isolation test volts 2kV)				
Supply DC					
Contact rating	SPDT: 10A @ 250VAC DPDT: 5A @ 250VAC				



Three Start Attempt Relay	Coincidence Relay	Over/Under Speed & Tacho Relay	Temperature Relay for T/C: J & K	Temperature Relay for T/C: PT100
Code	CS1	TM1	TRJ2	TR1
Outputs	SPDT	SPDT	TRK2	TR2
Mode of Operation	<i>Failsafe design.</i> External contacts A and B typically are pushbuttons mounted 1m + apart on a press or guillotine. The operator must press both buttons, keeping his hands safely away, before the machine operates. Apply the supply voltage. The contacts A & B must be actuated within 0.5s in order to make the relay operate. If one of the contacts is interrupted the relay will immediately release.  Ideal for use in machine safety guard systems.	<i>Failsafe design.</i> The Tacho relay connects to a PNP, NPN or Namur inductive or capacitive sensor. <b>Under Speed:</b> Link 5 & 11. The relay energises if input speed drops below the set limit. <b>Over Speed:</b> No link 5 & 11. The relay energises when the speed exceeds the set limit. <b>DIP SW:</b> SW1 ON: NPN SW1 OFF: PNP <b>Output TM4:</b> SW2 ON: 4-20mA SW2 OFF: 0-20mA  <b>Ranges:</b> Posn RPM Posn RPM 1 2-20 6 100-1k 2 5-50 7 200-2k 3 10-100 8 500-5k 4 20-200 9 1k-10k 5 50-500 10 2k-20k	<i>Failsafe design.</i> TRJ2 & TRJ4 for J type thermocouple <b>TRK2 &amp; TRK4</b> for K type thermocouple  The temperature relay connects to a temperature sensor. The relay energises when the temperature exceeds the set limit. The relay de-energises when the temperature drops below the set limit.  Remote control available on request.  AC Supply only	<i>Failsafe design.</i> <b>Link 8 &amp; 9: (under temp).</b> The temperature relay connects to a temperature sensor PT100. The relay energises when the temperature exceeds the set limit. The relay de-energises when the temperature drops below the set limit.  <b>NO Link 8 &amp; 9: (over temp).</b> The relay energises on application of power and will de-energise when the temp. exceeds the set value.
Connection Diagram				
Specification	Supply Voltage: 9-30VDC standard. Other Voltages available	TM1 - 1mA Output TM4 - 4-20mA Output 0-20mA Output TM4/R - Remote 1MV pot Hysteresis: 3% fixed Namur connect 6-7 NPN/PNP connect 5-6-7	Control: On/Off Proportional on request Latch: Pin 8 & 9 Hysteresis 3% fixed Faulty thermocouple Indication: Flashing LED	Overtemp: No link between PINS 8 & 9 Undertemp: Link 8 & 9 Hysteresis: 0 - 100%
Power consumption		AC: ±1.5VA DC: 100mA @ 12VDC		
Supply AC	Galvanic isolation with internal transformer 12, 24, 48, 110, 230, 400, 525VAC ±15% (Isolation test volts 2kV)			
Supply DC				
Contact rating	SPDT: 10A @ 250VAC DPDT: 5A @ 250VAC			

**POWER MONITORS**

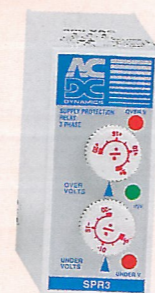
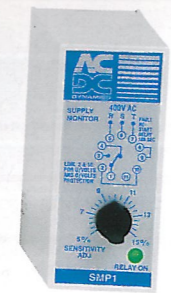

Type	Phase Failure & Sequence Relay		Supply Protection Relay		Over & Under Voltage Three Phase			
Code	SMP1 1000		SMP1 SMP1/N	SMP2 SMP2/N	SPR3	SPR3/N	TWCP1	TWCP1/N
Outputs	SPDT		SPDT	DPDT	SPDT		SPDT	
Mode of Operation	<p><b>Failsafe design.</b> This three phase (3 wire) unit monitors the supply voltage for all systems between 525 and 1000V. The output relay energises if the phases are all present and in the correct sequence. The relay de-energises when any phase is lost or the phase sequence is incorrect.</p> <p>The unit is housed in a DIN rail mounting housing suitable for 1000V connections.</p>		<p><b>Failsafe design.</b> This three phase (3 or 4 wire) unit monitors the supply voltages. The output relay energises if the phases are all present, in the correct sequence and each voltage is within 5-15% range (adjustable) of each other. The relay de-energises on:</p> <ol style="list-style-type: none"> <li>A phase voltage imbalance exceeding the adj limit (5-15%).</li> <li>Total failure of one or more phases.</li> <li>Incorrect phase sequence.</li> <li>Supply exceeds 15% under/over nominal voltage (Link 2-10 options).</li> </ol> <p>Built-in optional facilities (SMP1 &amp; SMP1/N only)</p> <ol style="list-style-type: none"> <li>180 sec fault restart delay.</li> <li>15% fixed over/under voltage.</li> </ol> <p>These facilities can be utilised by connecting external links as per the diagram below.</p>		<p><b>Failsafe design.</b> SPR3: 3 Phase (3 wires) SPR3/N: 3 Phase + N (4 wires) This three phase (3 or 4 wire) unit monitors the supply voltage and combines the protection features of the SMP1 and TWCP1. The output relay energises if the phases are all present, in the correct sequence and each voltage is to within the adjustable over and undervoltage limits.</p> <p>The relay de-energises on:</p> <ol style="list-style-type: none"> <li>Phase voltage imbalance exceeding the 10% (preset)</li> <li>Total failure of one or more phases.</li> <li>Incorrect phase sequence.</li> <li>Any phase falling outside the set voltage range.</li> </ol> <p>Built-in optional facilities:</p> <ol style="list-style-type: none"> <li>External latch N/C</li> <li>10 sec start up delay</li> <li>180 sec fault restart delay</li> </ol> <p>These facilities can be utilised by connecting external links as per the diagram below.</p>		<p><b>Failsafe design.</b> TWCP1: 3 Phase (3 wires) TWCP1/N: 3 Phase + N (4 wires) This three phase (3 or 4 wire) window voltage comparator monitors the supply voltage. The output relay energises if the voltage level is within the adjustable over and undervoltage limits and de-energises when the voltage is outside this range.</p> <p>Built-in optional facilities:</p> <ol style="list-style-type: none"> <li>External latch</li> <li>10 sec start up delay</li> <li>180 sec fault restart delay</li> </ol> <p>These facilities can be utilised by connecting external links as per the diagram below.</p>	

**Connection Diagram**

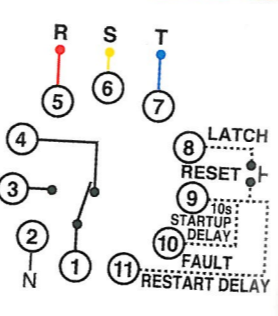
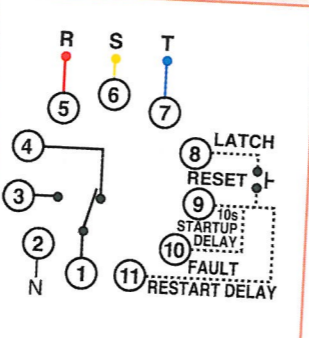
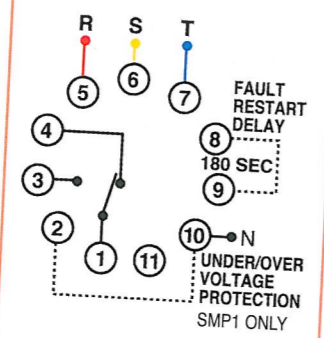
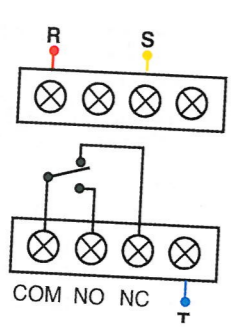

Specification	SMP1 & SMP2 - 3 Phase SMP1/N & SMP2/N - 3Phase + N	SPR3	TWCP1
LED:	Supply healthy - Green	Supply healthy - Green	Supply healthy - Green
DIN mounting housing	Available for 110, 230, 400V and 525V systems	Available for 110, 230, 400V and 525V systems	Available for 110, 230, 400V and 525V systems
Hysteresis	2% Fixed	2% Fixed	2% Fixed
Contact rating	SPDT: 10A @ 250VAC	DPDT: 5A @ 250VAC	SPDT: 10A @ 250VAC

**POWER MONITORS**

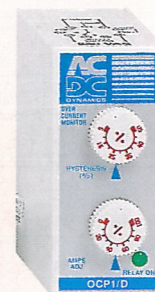

Over & Under Voltage Single Phase	Voltage Monitor	Over Current Monitor	Under Current Monitor	Over & Under Current Monitor	Over & Under Frequency Monitor				
Code	WCPT1	VCP1	VCP1/M	OCP1	OCP1/D	UCP1	UCP1/D	CWP1	FR1
Outputs	SPDT	SPDT	SPDT	SPDT	SPDT	SPDT	SPDT	SPDT	SPDT
Mode of Operation	<p><b>Failsafe design.</b> This new single phase window voltage comparator replaces WCP1 and monitors the supply voltage. The output relay energises if the voltage level is within the adjustable over and undervoltage limits and de-energises when the voltage is outside this range.</p> <p>Built-in optional facilities:</p> <ol style="list-style-type: none"> <li>External latch</li> <li>10 sec start up delay</li> <li>180 sec fault restart delay</li> </ol> <p>These facilities can be utilised by connecting external links as per the diagram below.</p>	<p><b>Failsafe design.</b> The output relay is energised when the voltage peak (peak voltage on AC) overshoots the level selected on the front face potentiometer. It de-energises when voltage falls below the normal voltage Ue by 5-50% or when supply breaks.</p> <p>The hysteresis is adjustable and its selection does not change the chosen voltage level.</p>	<p><b>Failsafe design.</b> OCP1 - 1A/5A AC/DC OCP1/D - 60mV/150mV AC/DC Trip Point - The relay de-energises when the input current rises above the set point and energises when the input current falls a certain percentage (hysteresis) below the set point.</p> <p>Hysteresis - The difference between the trip level and the set level.</p>	<p><b>Failsafe design.</b> UCP1 - 1A/5A AC/DC UCP1/D - 60mV/150mV AC/DC Trip Point - The relay de-energises when the input current drops below the set point and energises when the input current rises a certain percentage (hysteresis) above the set point.</p> <p>Hysteresis - The difference between the set trip level and the recovery level.</p>	<p><b>CWP1 - 1A/5A AC/DC</b> The relay senses the input current and the relay will energise, if the current is within the set overcurrent and undercurrent.</p> <p>The relay will de-energise if the current rises above the overcurrent setpoint or drops below the under-current setpoint.</p> <p><b>LEDs:</b> Over current - Red Under current - Red Supply on - Green</p>	<p><b>Failsafe design.</b> The unit senses the supply frequency and the relay will energise if the frequency is within the set over frequency limits.</p> <p>The relay will de-energise if the frequency rises above the over frequency setpoint or drops below the under frequency setpoint.</p> <p><b>LEDs:</b> Link 6 &amp; 5: Under Hz Link 6 &amp; 7: Over Hz</p>			

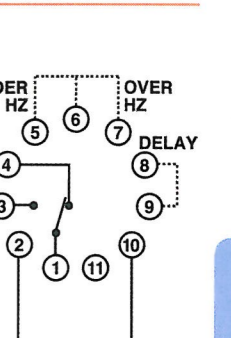
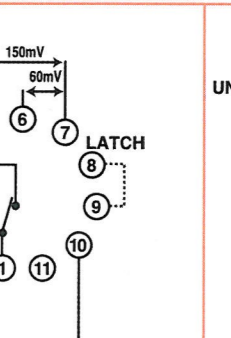
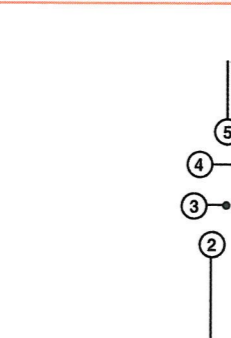
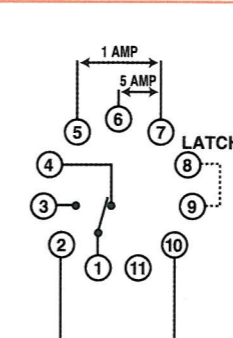
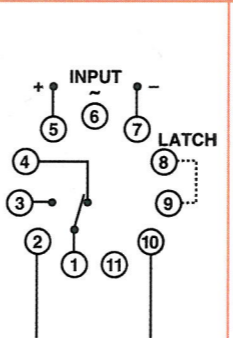
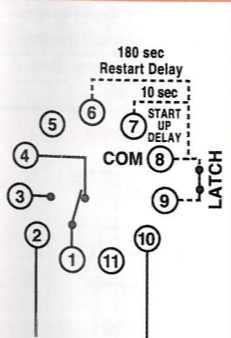

WCPT1	VCP1/M: Multi voltage inputs:	UCP1 OCP1 CWP1	UCP1/D OCP1/D	FR1
<p>Link 8 &amp; 9 External latch N/C Link 8 &amp; 7 10 sec start up delay. Link 8 &amp; 6 180 sec fault restart delay. Overvolts 5 - 30% ADJ. Undervolts 5 to 30% ADJ. <b>LEDs:</b> Over voltage - Red Under voltage - Red Supply healthy - Green</p>	<p>Connect:</p> <ul style="list-style-type: none"> <li>5-8 0-10VAC (RMS) DC</li> <li>6-8 0.4-40VAC (RMS) DC</li> <li>7-8 4-400VAC (RMS) DC</li> <li>11-8 6-600VAC (RMS) DC</li> </ul>	<p>UCP1 OCP1 CWP1 Input: AC: 0 - 1A Pins 5 + 7 0 - 5A Pins 6 + 7 Startup delay: 10 seconds For external pot use 10kV</p>	<p>UCP1/D OCP1/D DC: 0 - 150mV Pins 5 + 7 0 - 60mV Pins 6 + 7</p>	<p>Response delay: 1 sec Over: 52 - 58Hz adjustable Under: 48 - 42Hz adjustable <b>LEDs:</b> Over frequency - Red Under frequency - Red Supply on - Green</p>
2% Fixed	5 - 50% Adjustable	5 - 50% Adjustable	2% Fixed	2% Fixed

## LEVEL AND PUMP CONTROL



Type	Capacitive Level Relay		Flip-Flop Relay Pulse Start		Flip-Flop Mains Controlled		Pump Sequence Control Relay	
Code	CLR1	CLR2	FNCP1	FFCP1	FFP1	FFP2	FFP3	FFP4
Outputs	SPDT		SPDT	SPDT	SPDT	DPDT	3 Pumps	4 Pumps

**Mode of Operation**

**CLR1**  
*Failsafe design.*  
**Using NPN Probe**  
**Filling:** The relay energises when the level drops below the lower level sensor and de-energises when it reaches the high level sensor.  
**Emptying:** As above with opposite function. Link 7 & 9.  
**Using PNP Probe**  
Functions reverse.  
NPN Sensor: **SD10G-ARN1** Page 32  
NPN Sensor: **CS-09** Page 211

**CLR2**  
2 Wire Probe connection:  
Probe 1 5(+) 6(-)  
Probe 2 7(+) 6(-)  
Probes **VR1A** or **VR1B** Pg. 32.  
Single Probe connection:  
Probe 5(+) 7(-)

**FNCP1 (No memory)**  
Closing of contact across 5 & 7 the relay will energise. Closure of contact again, the relay will de-energise. When the relay is in the ON position and the supply voltage is removed, the relay will reset. (No memory).

**FFCP1 (With memory)**  
Closure of contact across 5 & 7, the relay will energise. On closure of the contact again the relay will de-energise. The relay remains in this position even on removal of supply. (with memory).

**Mains controlled: Change on removal of supply.**  
The relay is initially in any state, on or off, apply supply voltage. The relay keeps its state. Remove the supply voltage. The relay will now change state and will keep its state without the supply. Apply and remove the supply again for the next change in state.

**Mains controlled: Change on application of supply.**  
Link pins 5 and 7 (**Link A**). Apply supply voltage. The relay changes state. Remove supply. The relay keeps its state.

**Pulse controlled.** Link pins 6 and 7 (**Link B**). The relay is initially in any state, apply supply voltage. The relay keeps its state. When the contact between pins 5 and 7 closes, the relay will change state. Remove the supply voltage. The relay will keep its state without the supply. Minimum time supply connected for relay to react: 1 second.

**Float or Pressure switches are connected to pins 1, 11, 6 and common on 5.**  
When the first switch closes, relay 1 energises. When the second and third switches close, the second and third relays energise. There will always be as many relays energised as there are input switches closed. When 1, 2 or 3 pressure switches open, 1, 2 or 3 relays will de-energise. The positions of the pressure switches do not matter, only how many are switched on at a time. When all switches open and no relays are energised, and a switch closes again, then relay 2 will be the primary relay, that is the first relay to energise, then relay 3, and then relay 4 or 1. Every time the first switch closes, the next relay will be the first to energise.  
The supply must be connected for the relays to energise. The currently selected primary relay is stored in non-volatile memory. The relay will remember which relay to energise first, even if the supply is disconnected.

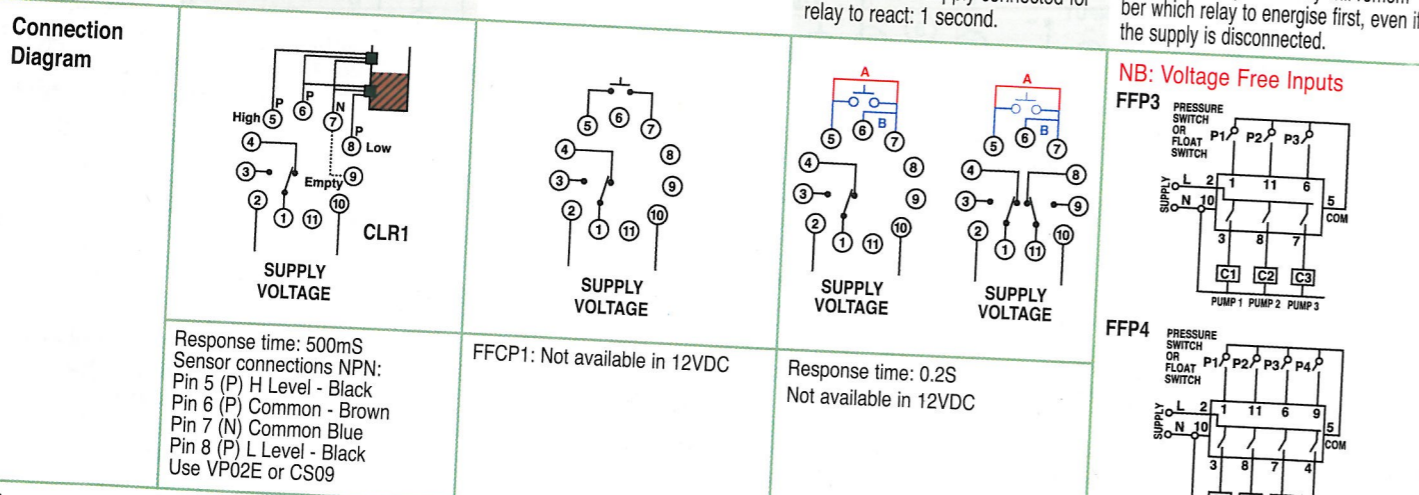

**Power consumption** AC: ± 1.5VA DC: 100mA @ 12VDC

**Supply AC** Galvanic isolation with internal transformer 12, 24, 48, 110, 230, 400, 525VAC ±15% (Isolation test volts 2kV)

**Supply DC** 12, 24, 48VDC

**Contact rating** SPDT: 10A @ 250VAC DPDT: 5A @ 250VAC

**M1** See also Phase Angle relays Page 41

## LEVEL AND PUMP CONTROL



2-Level Liquid Level Relay		3-Level Liquid Level Relay		Submersible Pump Seal Monitor
TE101	TE201	DLR	DLRA	SPSM1
SPDT	DPDT	DPST		SPDT

**TE101B:** Dual voltage 230/400V

**For Probes, see Pg. 32**

**Failsafe design.**  
**Filling:** Link 7 & 8. The relay energises when the level drops below the low level probe and de-energises when it reaches the high level probe. Top and bottom probes are interchangeable.  
**Emptying:** No link between 7 & 8. The relay energises when the level reaches the high probe and de-energises when it drops below the low probe.  
• For single level sensing connect pins 5 & 6 (Probes 5 & 7).  
• 1s response time to limit effect of water ripple. Longer times manufactured to order.

**Failsafe design.**  
**DLR**  
**For alternating pumps**  
There are two relay outputs with flip-flop action each cycle for alternating duty of pumps. Relay is connected to four probes.  
**Filling:** Link 7 & 8. Pump 1 starts when the level drops below the start level probe. Pump 2 will start if the level drops to the second probe. Both pumps run until tank is full. The next cycle pump 2 first then pump 1.  
**Emptying:** No link between 7 & 8. Function as above but reversed.  
**DLRA**  
**For one pump & alarm**  
Output relay energises and de-energises between 2 levels like TE101. When extreme level is reached, the alarm output energises (2nd Relay).  
Alarm can be used for high or low function.  
For Probes, see Pg. 32

**Failsafe design.**  
For protection of submersible motors against damage caused by the ingress of water.  
Terminals 5 & 7 connect to the monitoring terminals on the submersible motor.  
The output relay energises upon application of power. The relay will de-energise if probe current is more than 20µA or if probe resistance is less than 1Mohm. The relay will energise if probe current is less than 15µA or if probe resistance is more than 1,4Mohm.

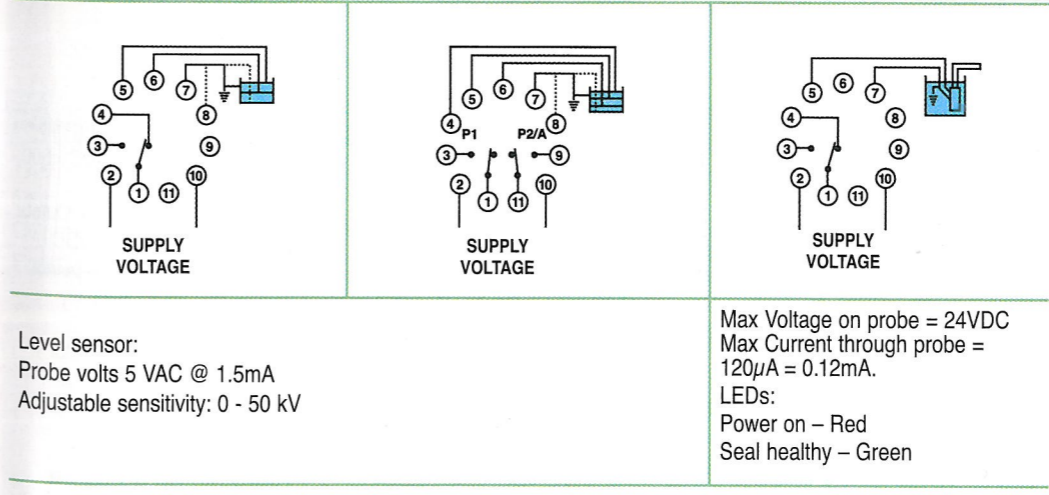

**Power consumption** AC: ± 1.5VA DC: 100mA @ 12VDC

**Supply AC** Galvanic isolation with internal transformer 12, 24, 48, 110, 230, 400, 525VAC ±15% (Isolation test volts 2kV)

**Supply DC** 12, 24, 48VDC

**Contact rating** SPDT: 10A @ 250VAC DPDT: 5A @ 250VAC

## ACCESSORIES

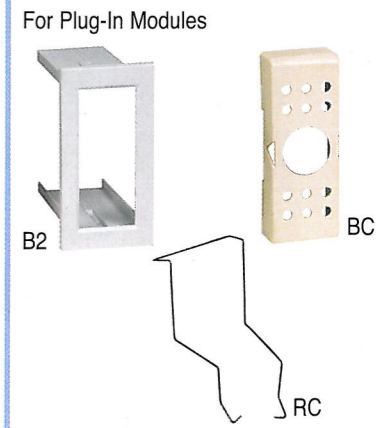

Accessories	Code
Timer box - Black	A1024BK
Retaining clip	RC
11 Pin base cover	BC
Bezel for panel mount	B2
Remote pot. 1mV	POT 1MEG
Remote pot. 10kV	POT 10K

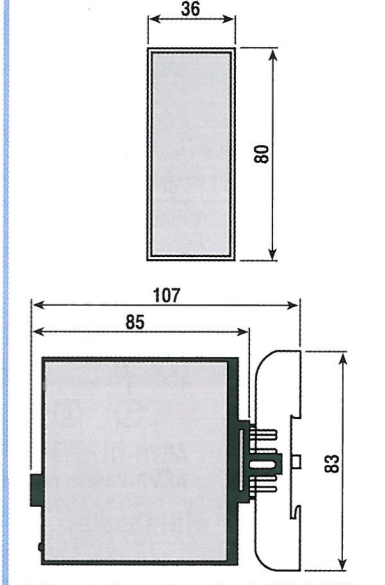

External dimensions (mm) A1024BK

**Standard time ranges**

0.02 - 1 sec	0.05 - 30 min
0.05 - 3 sec	1 - 60 min
0.20 - 10 sec	2 - 120 min
0.50 - 30 sec	3 - 180 min
1 - 60 sec	0.08 - 5 hours
3 - 180 sec	0.1 - 6 hours
6 - 360 sec	0.13 - 8 hours
10 - 600 sec	0.26 - 16 hours
0.25 - 15 min	0.4 - 24 hours

All timers, 11 Pin and 8 Pin, above 360 seconds: prices differ.

**8-Pin plug in timers**

The following timers are available in 8 Pin: DP1, DP2, DP3, IP2, IP3, EP1, EP2, UP1, UP2, DDP1, DDP2, DDP3, DAP1, IAP1, SDP1, PP1, TSP1 and OSP1.

**DIGITAL POWER MONITORS**



<b>Operation</b>	Digital 3-Phase Voltage Relay 0-999	Digital Frequency Relay 0-99.9
<b>Code</b>	<b>AEVR-YH</b> 400VAC <b>AEVR-Y4</b> (400VAC+N)	<b>AEFR-Y</b>
<b>Output</b>	Relay 5A @ 250VAC	Relay 5A @ 250VAC
<b>Mounting</b>	8 PIN plug-in/Flush mount	8 PIN plug-in/Flush mount
<b>Specification</b>	<ul style="list-style-type: none"> <li>Over and Under Voltage detection which is adjustable.</li> <li>Over and Under Voltage Trip Delay adjustable 0.1-10 sec.</li> <li>Phase Loss Detection.</li> <li>Phase Sequence detection.</li> <li>Phase Imbalance.</li> <li>Manual/Auto Reset with 1-5 sec trip delay.</li> <li>Cutout Size: 62 x 50mm.</li> </ul>	<ul style="list-style-type: none"> <li>Over Frequency: 50Hz-99Hz.</li> <li>Under Frequency: 10Hz-60Hz.</li> <li>Trip Delay: 1-10sec.</li> <li>Manual/Auto Reset with 1-5 sec trip delay.</li> <li>Cutout Size: 62 x 50mm.</li> </ul>

**DIGITAL MULTI-RANGE TIMER**



<b>Operation</b>	Digital Delay On Timer 0.025 to 99H99M
<b>Code</b>	<b>AS14S</b>
<b>Output</b>	Relay 5A @ 250VAC
<b>Mounting</b>	11 PIN plug-in
<b>Specification</b>	<ul style="list-style-type: none"> <li>Delay on Operation.</li> <li>Supply Voltage: 230VAC, 110VAC, 24VAC/DC, 12VAC/DC.</li> <li>Accuracy: &lt; 0.3%.</li> <li>Power consumption: &lt; 3W.</li> <li>Master reset on closure of contact on Pins 5 &amp; 6.</li> <li>Pause on closure of contact on Pins 5 &amp; 6, timer will continue on opening of contact.</li> </ul>

**SIGNAL CONVERTER/ISOLATOR**



<b>Operation</b>	Signal Converter/Isolator
<b>Code</b>	<b>ETK-MT3</b> (14-36VDC)
<b>Output</b>	Programmable Analogue + Alarm (open collector) min/max
<b>Mounting</b>	DIN Mounting
<b>Specification</b>	<p>Microprocessor based intelligent module for temperature sensor and other analog signal inputs. ETK-MT offers:</p> <ul style="list-style-type: none"> <li>conversion capability from low level input signal into high level standard output</li> <li>linearization and/or modification of the measured value</li> <li>galvanic isolation between input and output</li> <li>min and/or max alarm threshold with common output.</li> </ul>

**Connection Diagram**

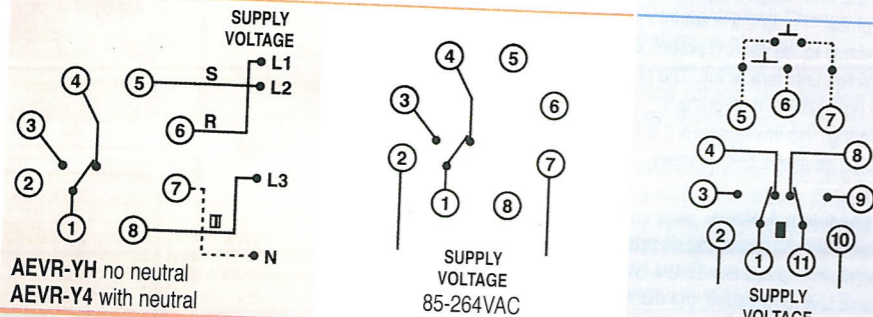

**Digital Timer with Display**



<b>Range</b>	9999 (S) (H) (M), 99M 59S, 99H 59S, 99 Days 23H
<b>Code</b>	<b>NT-411</b>
<b>Supply:</b>	AC: 110 and 230VAC
<b>Diagram:</b>	
<b>Contacts:</b>	5A @ 250VAC
<b>Operation:</b>	4 digit setting & display timer with multi output mode: delay auto reset. Auto/man reset and self hold. Instant reset. Remote start/stop and reset.
<b>Mounting:</b>	72 x 72mm

**DIN Timers**



Description	Time Range	Code
Delay on Timer	0.1-10secs	<b>NTE8-10B</b>
	10-120secs	<b>NTE8-120B</b>
	0.5-8mins (480secs)	<b>NTE8-480B</b>
Pulse Start Interval Timer	0.5-8mins (480secs)	<b>NTE8-480A</b>
Contact:	N/O 5 Amp @ 230VAC	
Supply:	230VAC	
<b>Connection Diagram</b>		

**Specifications:**

- Input Programme: TC/RTD (3 & 4 Wires)
- Range & Minimum Span (Programmable)
- Digital Input Filter (high noise attenuation): 4 levels configurable
- Input Impedance: >1 mOhm (in V) >10 mOhm (in mV) >10 ohm (in mA)
- Open Input Detection (thermocouple): out > max +5%
- Sensor Current (RTD, resistance, potentiometer): 200µA (3 Wires) 400µA (4 Wires)
- Sensor Wire Resistance (RTD, resistance, potentiometer): <500 Ohm
- ETK-MT3 Programmable; Output 0-20/4-20mA 0-10/-5+5VDC
- Output Resolution: 4000 points
- Alarms: min and/or max (configurable by PC)
- Alarm Output: Open collector (isolated 2500Vrms)
- Sampling Time: 35msec
- Response Time: 200msec

**Programming Software**

**Code ETK-MT**  
Software package for the configuration of = input, working range, output type, digital filter and alarm thresholds

**NEW RANGE**

**MINI DIN TIMERS, STAIRCASE TIMERS & DIMMERS**

Timers  
Operating temp: -20 to 60°C



Code	PCM-04*	PCM-10*	PCM-01*	PCM-01/U (12-240VAC/DC)	PCM-02*	PCM-02/U (12-240VAC/DC)	PCM-06/U
<b>Type</b>	Multi-functional Timer	Multi-functional Timer	Delay ON	Delay ON	Delay OFF (Internal)	Delay OFF (Internal)	Delay OFF (no power) or Delay ON
<b>Output Relay</b>	1 C/O - 16A	1 C/O - 16A	1 C/O - 16A	1 C/O - 16A	1 C/O - 16A	1 C/O - 16A	2 C/O 8A
<b>Function</b>	This multi-function timer has 10 independant operating modes. Wide time adjustment 0.1sec to 10 days. • Delay ON operate. • Delay OFF (Interval). • Repeating starting with OFF. • Repeating starting with ON • Delay pulse on 0.5 secs • Interval pulse start on rising edge. • Interval pulse start on falling edge. • Bistable relay with time delay • Switch ON/OFF delay. • Interval pulse start with retriggering.	This multi-function timer has 10 independant operating modes. Wide time adjustment 0.1sec to 100 days. • Unequal repeating OFF first. • Unequal repeating ON first. • Two shot timer ON first. • Two shot timer OFF first. • Permanent switch ON mode. • Permanent switch OFF mode. • Switch ON pulse start T1 and pulse OFF T2 delay. • Pulse start interval T1, second pulse T2. • ON pulse OFF starts T1 & T2	The one mode time relay has a delayed switch on function. The relay is released by power to the system. Wide time adjustment range: 0.1sec to 10 days. Power & Relay ON LED. Accuracy 0.2%.	Upon application of the supply voltage the relay operates and the time starts. On the expiry of the set time the relay releases. The relay is reset by Power OFF to the relay. Wide time adjustment range: 0.1sec to 10 days. Power & Relay ON LED. Accuracy 0.2%.	<b>Mode A:</b> On application of the supply voltage the relay operates when the supply volage is disconnected the timer period starts. After the adjusted time is over the relay releases. Time ADJ 0.15s-10m for delay OFF. Time ADJ 0.1s-1h for delay ON Power & Relay on LED Accuracy 0.2% <b>Mode B:</b> Delay ON operation		
<b>Supply</b> * Add voltage to code	*230VAC, *24V(AC/DC)	*230VAC, *24V(AC/DC)	*230VAC, *24V(AC/DC)	*230VAC, *24V(AC/DC)	*230VAC, *24V(AC/DC)	*230VAC, *24V(AC/DC)	12-240VAC/ DC
<b>Operating temp:</b>	-20 to 45°C	IP65			IP40		
<b>Code</b>	<b>PCM-03*</b>	<b>PCM-03/U</b> (12-240VAC/DC)	<b>ASH-01/U</b>	<b>ASM-01/U</b>	<b>DIP-02</b>	<b>DIM-20</b>	
<b>Type</b>	Cycling Timer	Cycling Timer	Staircase Timer	Staircase Timer	Light Dimmer	Light Dimmer	
<b>Time</b>	0.1 Sec - 10 Days	0.1 Sec - 10 Days	10 Sec - 10 Min	10 Sec - 10 Min	-	-	
<b>Output relay</b>	1 C/O - 16A	1 C/O - 16A	1NO - 16A	1NO - 16A	-	-	
<b>Function</b>	The one mode time relay has an equal ON/ OFF repeating time delay starting with OFF. Wide time adjustment range: 0.1sec to 10 days Power & Relay ON LED. Accuracy 0.2%.	Staircase, corridor time delay device. Operating time adjustable from 10 secs to 10mins by means of potentiometer. 2 Way switching. 3-wire or 4-wire installation. Size: 69 x 56 x 27mm	Similar to ASH-01 but in DIN Power: Red LED indication Time adjustment: 10 secs to 10mins 1 Module width	Light intensity memory. Compact Design. LED indicator. 3 Wire design. Can fit into 4x2 flush box. Triac Output. Wiring: Black: Live Brown: Load Red: Switch Size: 50 x 50 x 26mm Max load: 350VA Resistive load Min load: 30VA	Intelligent dimmer lighting control unit for resistive, inductive loads or electronic ballasts and dimmable energy saving flourescent lamps. DIN Rail Mount. LED indicates load on. Lighting level memory when power OFF. Energy saving in Stand-by mode. Max load: 500VA Resistive or inductive load. Min:30VA		
<b>Supply</b> * Add voltage to code	*230VAC *24V (AC/DC)	12-240VAC/ DC	12-240VAC/ DC	12-240VAC/ DC	230VAC	230VAC 50/60Hz	

AUTOMATION PRODUCTS

AUTOMATION PRODUCTS

PHASE FAILURE, VOLTAGE, DAYLIGHT & TEMPERATURE RELAYS

Operating temp: -20 to 60°C

NEW RANGE



Code	CKM-01	CKH-01	PNM-10	PNM-31	PNM-32
Type	3 Phase Failure & Sequence	3 Phase Failure & Sequence	1 phase Over/ Under Voltage Relay	3 phase Over/ Under Voltage Relay	Digital Display Over/ Under Voltage Phase Failure
Output Relay	1 C/O - 10A	1 C/O - 10A	1 C/O - 10A	1 C/O - 16A	1 C/O 16A
Function	Phase sequence, total and partial loss monitoring device. Monitors wrong phase sequence, or loss of one phase. < 180V Switch on Delay: 5-10 Secs Switch off Delay: 1-5 Secs Voltage Threshold ADJ 170 - 200V Hysteresis ±10V Correct / wrong phase seq. LED	Phase sequence, total and partial loss monitoring device. Monitors wrong phase sequence, or loss of one phase. < 180V Switch on Delay: 5-10 Secs Switch off Delay: 1-5 Secs Voltage Threshold 185V Hysteresis ±10V Correct / wrong phase seq. LED	Over/ under Voltage monitoring relay. Single phase monitoring Minimum and Maximum voltage adjustment Min value: 170V - 225V Max value: 235V - 290V Switch off time delay adjustment: 0 to 12Secs	Over/ under Voltage monitoring relay. Three phase monitoring Minimum and Maximum voltage adjustment Min value: 170V - 225V Max value: 235V - 290V Switch off delay 5 secs Phase seq. LED Voltage asymmetry LED L1, L2, L3 phase LED Relay ON LED	Protection of 3 phase systems against: • Phase sequence • Phase failure • Over/ Under volts adjustable 170-225V 235-290V phase to neutral volts • Features: - Delay ON time setting 2-15s - Delay OFF time setting 2-15s - Voltage hysteresis 1-4V - Voltage asymmetry level setting 10-60V
Supply	Powered from own supply 400V + N	Powered from own supply 400V + N	230VAC 50/60Hz	Powered from own supply 400V + N	Powered from own supply 400V + N

Operating temp: -20 to 45°C

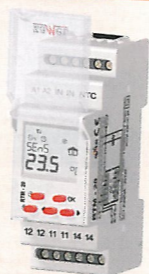
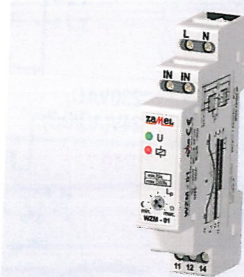

Code	WZH-01	WZM-01	RTM-01	RTM-20	RTM-30
Type	Daylight Relay	Daylight Relay	Temperature Regulator	Digital Temp Regulator	Digital Temp Regulator
Supply	230VAC 50/60Hz	230VAC 50/60Hz	230VAC, 50/60Hz	230VAC 50/60Hz	230VAC 50/60Hz
Output relay	1NO - 16A	1 C/O - 16A	1 C/O - 16A	1C/O - 16A	1C/O - 16A
Function	Used to control lighting depending on lux density levels. The unit is resistant to momentary changes in lighting levels Lux adj 0.1 to 200Lx Photocell included Size: 69 x 56 x 27mm Switching delay: 30S Hysteresis: +5-60Lux	Used to control lighting depending on lux density levels. The unit is resistant to momentary changes in lighting levels Requires Light Sensor Lux adj 0.1 to 200Lx Sensor cable max length 50m Switching delay: 30S Hysteresis: +5-60Lux	DIN mounted temperature controller. -5°C to 40°C. Underfloor heating etc. For use with standard NTC sensor, from 3m to 50m (See below)	RTM-20: -5°C to 60°C. RTM-30: -10°C to 90°C Underfloor heating etc. LCD display No freeze, comfort, economy modes Indication of temp value and adjustable temp required. 24hr 7day ON/ OFF settings RTM-20 Heating only RTM-30 Heating & cooling For use with standard NTC sensor, from 3m to 50m. (See below)	RTM-20: -5°C to 60°C. RTM-30: -10°C to 90°C Underfloor heating etc. LCD display No freeze, comfort, economy modes Indication of temp value and adjustable temp required. 24hr 7day ON/ OFF settings RTM-20 Heating only RTM-30 Heating & cooling For use with standard NTC sensor, from 3m to 50m. (See below)

**Daylight Sensor**  
Code SOH-\*  
The SOH-0\* is designed for operation with the Daylight Switches.  
\*01: 1m connecting cable.  
\*03: 3m connecting cable  
\*05: 5m connecting cable

**Daylight Sensor**  
Code SOS-01  
The SOS-01 is a stand-alone sensor. To be used with WZM-01. The length of the interconnecting cable may not exceed 50m.

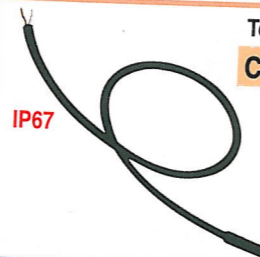

**Temperature Sensor**  
Code NTC-03  
For use with the RTM-01 and RTM-20 temperature regulator. Cable length: 3m (can be extended up to 50m) Temperature -5°C to 60°C

VOLTAGE & CURRENT RELAYS

NEW RANGE

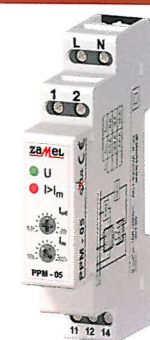
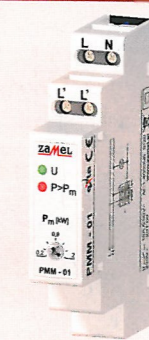
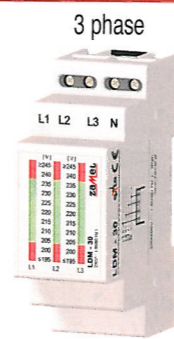

Code	LDM-10	LDM-30	PMH-01	PMM-01	PPM-05/5 (0.5-5A) PPM-05/16 (1.6-16A)
Type	Voltage Indicator		Over Current Limiter	Over Current Limiter	Load Control Relay
Output Relay	-	-	1 NO - 16A AC1 4kW	1 NO - 16A AC1 4kW	1 C/O - 16A AC1 4kW
Function	The module is used for graphical presentation of either one phase or three phase voltage supply system levels. The voltage value is shown by lines of LEDs. Range from 195V to 254VAC PH/N <b>LDM-30 Loss of L1 will cause total switch off</b> Input voltage tolerance: -15-10%		Used to monitor and switch off supply when the Load power value has been exceeded, Adj: 0.2 - 2kW. Unit measures current every 40 secs.	Used to monitor and switch off supply when the Load power value has been exceeded, Adj: 0.2 - 2kW. Unit measures current every 40 secs.	When the adjusted current value is exceeded (term 1, 2) the monitor switches off the non-priority load, with the adjusted time delay. Current values and time delay can be adjusted.
Supply	LDM-10: 1 phase 230VAC monitoring LDM-30: 3 phase 400 VAC + N monitoring		230VAC 50/60Hz	230VAC 50/60Hz	230VAC 50/60Hz

Operating temp: -20 to 45°C

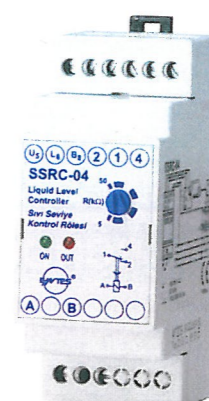
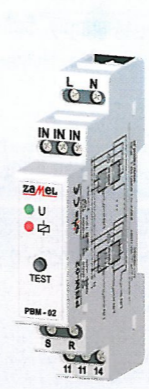
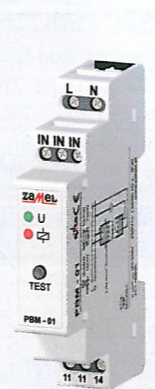

Code	PBM-01*	PBM-02*	SSRC-04*
Type	Bi-stable Relay		Liquid Level Relay
Supply	*230VAC or *24V (VAC/DC)		*230VAC, 400VAC
Function	Used to control lighting or other devices by means of a pushbutton in parallel. Pushing any button causes switching on or switching off. L or N line signal PBM-02. Internal relay memory remembers position of relay when power fails. Can be centrally controlled.		SSRC-04 is used for the level and discharge control of conductive liquids in tanks located in industrial plants and domestic applications. The output relay switches ON when the liquid reaches the upper level electrode. The output relay switches OFF when the lower level electrode is no longer in contact with the liquid. The sensitivity (i.e. impedance between electrodes) can be adjusted to 5-50Ω for different liquids by means of the knob of the front panel. The LED on the front panel lights when the relay is ON position.
Output relay	1NO @ 16A AC 1 4kW		1C/O 8A
LED Indication	LED Green: Power LED LED Red: Relay on LED Test button		LED Green: Power LED LED Red: Relay on LED
Dimensions	17.5mm width DIN mounting		35mm width DIN mounting

On application of the supply voltage, the relay will energise, and the geyser will switch on. Current adjustment can be set so that if one stove plate is on, the geyser will remain on. When the second stove plate is switched on the geyser will be switched off after an adjustable time delay. Current can also be set so that even if one stove plate is switched the geyser will switch off. Use PPM-05/16 for 3kW geyser. Use PPM-05/5 with CT's for larger loads. For geysers use external contacts.

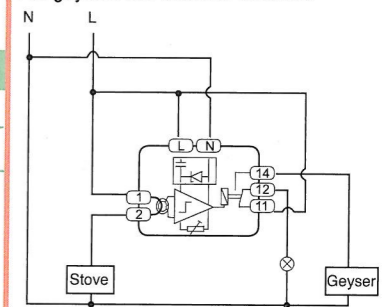

⊗ = Lamp to indicate that geyser is off. Stove load not to exceed 16 Amps, if larger use external CT. Eg. DS-505 50/5A with relay PPM-05/5.

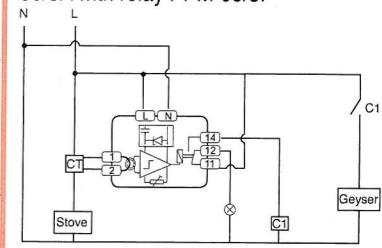

**MINI DIN TIMERS, VOLTAGE & CURRENT RELAYS**

**Monitoring Relays**

CARLO GAVAZZI

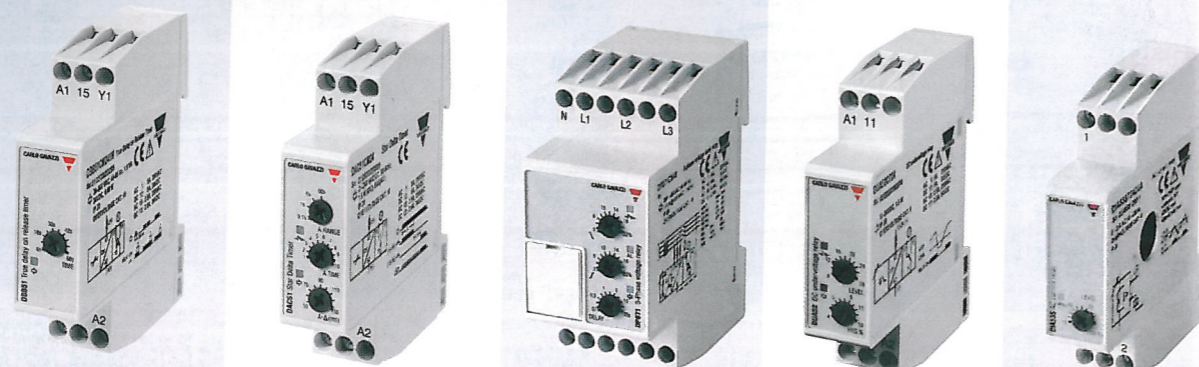

35.5mm wide

Code	DBB51C M24*	DAC51C M24	DUB71C B23*	DUA52C 724	DIA53S 724*
Type	Delay off	Star-Delta	Over/Under Voltage	Battery Monitor	Over Current Monitor
Output	SPDT 5A @ 250VAC	SPDT (with neutral posn) 5A @ 250VAC	SPDT 5A @ 250VAC	SPDT 5A @ 250VAC	NPN-PNP open collector NO(1)
Input	-	-	0.1-10V AC/DC *10V 2-500V AC/DC *500V *Add to order Code	8-28VDC	2-20A AC *20A 5-50A AC *50A 10-100A AC *100A
Function	True delay on release. *Time ranges: 1s - 10s <b>10s</b> 6s - 60s <b>1m</b> 60s - 600s <b>10m</b> DBB51 should not be operated by pulses <200ms.	For use with Star-Delta motor starters. Ranges: 0.1s - 1s; 1s - 10s; 6s - 60s; 60s - 600s. Adj. delay between Star and Delta 50 to 130ms.	Over/Under Voltage monitoring relay. 1 Phase AC/DC TRMS comparator. Set-point adjustable. Hysteresis adjustable. Time delay adjustable. For 0.1-10V CT see page 116	Under voltage monitoring relay for DC battery circuits. Measures own power supply. Self-point adjustable. Hysteresis adjustable.	Over current monitoring relay. 1 Phase AC set-point adjustable 2 wire connection. Integral CT with 12mm dia hole. *Add CT range to order Code. (1)100mA 40VDC max
Supply	24VDC/24 to 240VAC	24 to 240VAC/DC	115/230VAC	Taken from input	12-24VDC

**DIGITAL SCHOOL TIMER**

**Electronic School Timer**

Code	No. of channels	Time Range	Total no. of programmes	Working Reserve	Minimum Interval	Width in DIN	Relay Output
SDM-10/U	1	24hrs/7 days	50 on + 50 off	3 years	1 sec.	2	16A, C/O

User friendly, and easy to program. Lesson times can easily be added or changed. The controller has a real time clock and calendar.  
Adjustable ringing duration.  
Width: 35mm (2 Module width)  
Complete with protective flap.

Supply Voltage: 24V - 230VAC/DC  
Relay output rated at 16A, AC1 rating.  
Battery backup, preventing data loss during power failure.  
LED illumination of the LCD display.  
Able to back up programmed times for 10 years.  
Seasonal and holiday programming available

**Electronic School Control Box**

Code	EW-01
------	-------

The Electronic School Janitor is an assembled unit. Used for controlling school utilizing the SDM-10. It consists of:

- Over Voltage Protection
- Bell Controller (SDM-10)
- Electromagnetic Relay x 2
- Alarm Button
- Acoustic Alarm Indicator
- Short period selection button

**Features:**  
Two ways of connecting directly to the school bell or connecting to the existing installation instead of manually ringing the bell.

- Easily programmable timetable.
- Real time clock.
- Adjustable ringing duration.
- Programmable alarm bells.
- Seasonal and holiday programming available

**ORBIS**

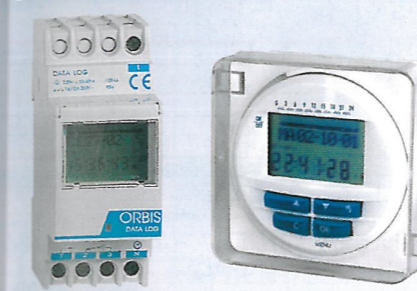

DATALOG

MINITLOG

**TIME SWITCHES**

**Orbis Digital time switches**

Code	No. of channels	Time Range	Total No. of programmes	Working Reserve	Minimum Interval	Width in DIN	Relay Output
DATALOG1†	1	24hrs/7days	50 on + 50 off	5 years	1 sec	2	16A,C/O
DATALOG2†	2	24hrs/7days	50 on + 50 off	5 years	1 sec	2	16A,C/O
MINITLOG†	1	24hrs/7days	50 on + 50 off	5 years	1 sec	Panel Mount 72 x 72	16A,C/O

†Specify voltage with order: 230VAC, 110VAC, 24VAC/DC, 12VAC/DC.

**Features:**

- Programming with text menus.
- Output pulse 1-59 secs programmable.
- Random programming for security lighting.
- Running hour counter.

**Lamp loads:**

Incandescent lamps	3000W
Uncompensated fluorescent	1200W
LV Halogen	1000W
230V Halogen	2500W

**Factory/School Time Switch**

**FTDE7** Complete with digital time switch in IP55 Gewiss (GW40001) enclosure 170 x 105 x 98mm.  
Programmable 50 On + 50 Off settings per week and block programming which enables programs to be repeated for each weekday or 6 or 7 days  
Duration of siren can be set from 1 to 59 sec.  
Supply: 230VAC. Relay output: C/O 16A @ 250VAC  
Reserve: 5 years  
Features as per DATALOG1

**VP-PROG** Programming Charge for FTDE7 Timer

For complete range of Audible and Visual Alarms see pages 239-253.

**Digital Time Switches**

Code	No. of channels	Time Range	Total No. of programmes	Working Reserve	Minimum Interval	Width in DIN	Relay Output
------	-----------------	------------	-------------------------	-----------------	------------------	--------------	--------------

**New - Annual/monthly/weekly/daily Time Switch**

**VP8700** 1 D/W/M/Y 25 on + 25 off 5 years 1 sec 2 16A,C/O  
• Supply Volts: 230VAC  
Features as per DATALOG1 without text menus but with additional programming:  
Monthly - every month on the same day.  
Annual - every year in the same month and on the same day, at a preset date during the year.

**4 Channel Timer**

**VP8031 \*** 4 7 days 12 on + 12 off 100hrs 1 sec 4 16A,C/O

\*Add voltage to code: 230VAC, 110VAC, 24VAC/DC, 12VAC/DC.

**Economy Digital Time Switch**

**TH-857-2 \*** 1 24hrs/7days 8 on + 8 off 200hrs 1 min 2 16A,C/O

\*Add voltage to code: 230VAC, 110VAC, 24VAC/DC, 12VAC/DC.

**Panel Fitted Daylight Switch**

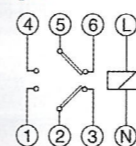

**Code ASTRO LOG**

Astro Log fits inside your distribution board. Programme in your co-ordinates and the Astro Log will control your lights perfectly, every day, every season.

Power Supply	230VAC (6VA)
Switching Capacity	16(10)A/250V AC 2C/O
Operating Accuracy	±1sec/day at 23°C
Switching Accuracy	Better than 1 second
Battery Back-up	4 years (Lithium battery)
Memory Spaces	22
Auto change summer/winter	Yes
<b>Max Recommended Load</b>	
Incandescent	3000W
Non-compensated Fluorescent	1200W



**Astronomic Weekly Timer/ Daylight Switch - 230VAC**

Just program in your geographical co-ordinates and the unit will do the rest. Can also use a photocell to give additional control.

Code	Description	Relay Output
------	-------------	--------------

DTR-14	Astronomic timer with photocell	2C/O (8A)
DTR-10	Astronomic timer	2 C/O (8A)
DTR-10T	Astronomic timer	1 C/O (16A)
FG-GOZ	Photocell sensor for DTR-14	-

Battery back-up: 5yrs.  
Super capacitor for additional 10hrs reserve.  
No. of programs: 15.  
Operating accuracy: ≤1 sec/day.

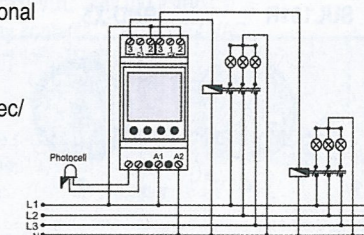

Connection Diagram

## TIME SWITCHES



Code	Type	Motor	Dial	Working Reserve	Minimum Switching time	Contact Rating @ 230V
<b>Alpha Type</b>						
AD	Alpha D	Synchronous	1 x 24h	-	15min	16A
AQRD	Alpha QRD	Quartz	1 x 24 h	100 hrs	15min	16A
AS	Alpha S	Synchronous	1 x 7 day	-	2hrs	16A
AQRS	Alpha QRS	Quartz	1 x 7 day	100 hrs	2hrs	16A

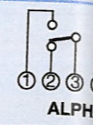

Code	Type	Motor	Dial	Working Reserve	Minimum Switching time	Contact Rating @ 230V
<b>Crono Type - DIN Mount or Panel Mount 72 x 72mm</b>						
CQRD	Crono QRD	Quartz	1 x 24h	100 hrs	15min	16A
CQRS	Crono QRS	Quartz	1 x 7 day	100 hrs	2hrs	10A
CDD	Crono DD	Synchronous	2 x 24h	-	30min	15min 10A
CQRDD	Crono QRDD	Quartz	2 x 24h	100 hrs	30min	15min 10A
CQRSD	Crono QRSD	Quartz	1 x 24h & 1x7 day	100 hrs	2hrs	20min 16A
CSM	Crono SM	Synchronous	1 x 7day & 1x120 min-	100 hrs	2hrs	2,5min 10A

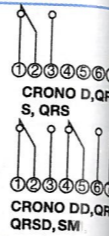

Code	Type	Motor	Dial	Working Reserve	Minimum Switching time	No of Mod	Contact Rating @ 230V
<b>Supra Type</b>							
SD	Supra D	Synchronous	1 x 24h	-	15min	2.5	16A
SQRD	Supra QRD	Quartz	1 x 24h	100 hrs	15min	2.5	16A
SQRS	Supra QRS	Quartz	1 x 7 day	100 hrs	2hrs	2.5	16A

New design includes replaceable battery from front.

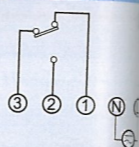

Code	Type	Motor	Dial	Working Reserve	Minimum Switching time	No of Mod	Contact Rating @ 230V
<b>Uno &amp; INCA DuoType</b>							
UD	Uno D	Synchronous	1 x 24h	-	15min	1	16A
UQRD	Uno QRD	Quartz	1 x 24h	100 hrs	15min	1	16A
UQRS	Uno QRS	Quartz	1 x 7 day	100 hrs	2hrs	1	16A
DD	INCA D	Synchronous	1 x 24h	-	15min	2	16A
DQRD	INCA QRD	Quartz	1 x 24h	100 hrs	15min	2	16A
DQRS	INCA QRS	Quartz	1 x 7 day	100 hrs	2hrs	2	16A

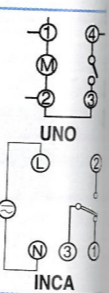

### Defrost (Refrigeration) Time Switches



FRI-600M	FRI	Defrost duration 5-55min	16A
<i>Ideal for freezer rooms where fan delay is required.</i>			
Time between Defrost minimum 2 hrs			

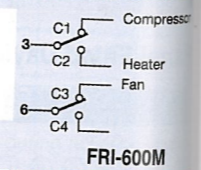

### Economy Time Switch



Code	Dial	Working Reserve	Minimum Setting	Width in DIN	Contact Rating
SUL181R	24h	150 hrs	30 min	2	16A
BND-X5	24h	150 hrs	30 min	1	16A

*Ideal for swimming pool pump control*

### Plug In-Mains Timers



Code	Dial	Working Reserve	Minimum Setting	Contact Rating
TS-MS1	24h	-	30 min	16A
TS-MS2	7 day	-	1 hr	16A
TS-30	7 day digital	100 hrs	1 min	16A

## SPECIAL TIMERS

Digital & Multi-Range Timers



Type	Multi-Range Function Multi-voltage Timer	Multi-Range Timer Multi-voltage	Digital setting & display (4 digit)	Multi-Range 4 digit timer	Miniature Timer
Code	AT11DN (2 delay) AT11EN (1 Del + 1 Inst)	AH5N (1S-600H) AH5N-S (6S-60min)	AH5F	SP3-48	AMY-2**
Relay Contacts	3A @ 250VAC	5A @ 250VAC	5A @ 250VAC	5A @ 250VAC	5A @ 250VAC
Operation	• Delay On • Delay Off (interval) • Delay On pulse start • Delay Off pulse start • Equal repeating On or Off first AT11DN (2 delay SPDT) AT11EN (1 delay + 1 instantaneous SPDT)	Mode A Delay on DPDT Mode B Delay on SPDT & instantaneous SPDT	Delay on SPDT & instantaneous SPDT	Delay on Up/down timing Start/Reset mode Programmable power-off memory	Delay on operate Contacts: DPDT
Size	48 x 48mm Panel Mount or 11 PIN Base, mounting bracket included	48 x 48mm Panel Mount or 8 PIN Base mounting bracket excluded (Y-50)	48 x 48mm Panel Mount or 8 PIN Base, mounting bracket included	48 x 48mm Panel Mount or 8 PIN Base, mounting bracket included	22 x 28mm Base Mount Base required ZM2VP
Time Range	0.05 - 10sec 0.05 - 10min 0.05 - 10 hour 0.05 - 10 (x10 hour)	0 - 1S 0 - 1H 0 - 10S 0 - 10H 0 - 1M 0 - 60H 0 - 10M 0 - 600H	999,9 sec 9999 sec 999,9 min 9999 min	Time Selections 9999HR 9999SEC 9999MIN 999,9SEC 999,9MIN 99,99SEC	*6 sec *10 sec *30 sec *60 sec *180 sec
Supply Voltage	24-240VAC/DC	24-240VAC/DC	35-240VAC/DC	12VAC/DC, 24VAC/DC, 110VAC, 230VAC	DC: *12, *24VDC AC: *24, *110, *230VAC
Connection Diagram					
Accessories	Y-50 Panel Mounting Bracket (48 x 48mm) for AH5N, AH5F & SP3-48	P3G-08 8 PIN Base with reversed terminals	P3G-11 11 PIN Base with reversed terminals	ZM2VP For Timer AMY-2	



<b>Multi Function Timer - 11 pin</b>	
Code	48T100-11-*
* Add voltage to code: 012 (12VDC), 024 (24VAC/ DC), 110VDC, 230 (100-230VAC)	
Relay contacts:	2 x 5A@250VAC
Operation:	Delay On (pulse start) Interval (hold/ pulse start) Equal repeating (ON/ OFF first) Signal ON/ OFF delay
Features:	Gate Input - when activated the unit stops timing and continues when released.
Time range:	0.1sec-100hrs in 8 overlapping ranges
Size:	48 x 48mm

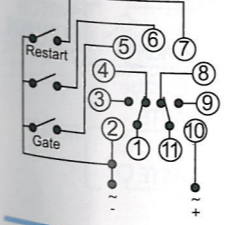

<b>Delay ON/ interval timer - 8/11 pin</b>	
Code	48T101-+†
*Add no pins to code: 08, 11 †Add voltage to code: 012(12VDC), 024(24VAC/ DC), 110VDC, 230(100-230VAC)	
Relay contacts:	2 x 5A@250VAC
Operation:	Delay ON Delay OFF (interval)
Time range:	0.1sec-100hrs in 8 overlapping ranges
Size:	48 x 48mm

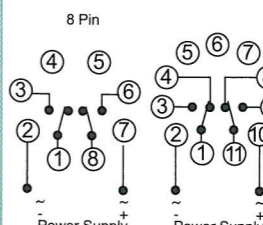

**DIGITAL TIMERS & COUNTERS**

Type	Timer	Timer/ Counter	Pre-set Counter	Up/ Down Totalizing Counter	Total Counter/ Hour Meter
<b>RHOMBERG</b>					
	6 timing functions	Auto or Manual reset	Auto or Manual reset	Manual or Electronic reset	
<b>Code</b>	<b>DHC48</b>	<b>DHC10J</b>	<b>DHC5J</b>	<b>DHC9J-J</b>	<b>DHC15J</b>
Size(mm)	48 x 48 x 92	48 x 48	48 x 48 x 92	36 x 72 x 77	2 Module DIN mount
Panel Cutout	45 x 45	45 x 45	45 x 45	33 x 68.5	2 Module DIN mount
Range	Delay ON/ Interval/ Equal Repeating. 0.01s-99h59m	Timer: 0.01s-99h59m Counter: 0-9999	0-9999	0-9999	0-99999999
Counting Speed	-	30/500cps	30/1000cps	30/1000cps	10cps
Display	0.3 inch LED (4 digit)	2 line 4 digit LED	0.3 inch LED (4 digit)	0.56 inch LED (6 digit)	8 digit LCD display
Power Supply	100-240VAC/DC	100-240VAC/DC	100-240VAC/DC (12-24VAC/DC)	100-240VAC/DC	100-240VAC/DC
Input Single	Pulse Start & Reset	Contact or solid-state [H]: 4-30V [L]: 0-2V Input $\geq 4.7k\Omega$	Contact or solid-state [H]: 4-30V [L]: 0-2V Input $\geq 4.7k\Omega$	Contact or solid-state [H]: 4-30V [L]: 0-2V Input $\geq 4.7k\Omega$	DC 4-30V
Output	2 C/O 3A 250VAC	1 C/O 3A@250VAC	1 C/O 3A@250VAC	NO	NO
Memory backup	-	10 years	10 years	10 years	5 years

**DIGITAL TIMERS**

**RHOMBERG**

24 Hour

7 Day

Code	DHC20	DHC15A
	<ul style="list-style-type: none"> <li>Easy to program</li> <li>Directly at DIN rail 54 x 60mm</li> <li>Minimum switching time 15 mins</li> <li>Manual ON/ OFF/ AUTO override</li> <li>SPDT 16A (Resistive Load) switch</li> <li>LCD display with backlight</li> <li>48 ON/ 48 OFF programs</li> <li>Battery back-up: 150hrs</li> </ul>	<ul style="list-style-type: none"> <li>24 / 7 Day timer</li> <li>8 ON/ 8 OFF programs</li> <li>SPDT 16A (resistive load) switch</li> <li>LCD display</li> <li>DIN rail 36 x 60mm</li> <li>Supply volts: 230VAC</li> <li>Minimum switching time 1 min</li> <li>Battery back-up: 150hrs</li> </ul>

**HOUR METERS**

**LCD Hour Meter**

Panel cut out 50 x 25mm

• 8 digit LCD Hour Meter. • Panel Mount. • External reset.

Range	Input	Code
999999H59M	80-250VAC	<b>LT8MA1</b>
999999H59M	Contact	<b>LT8MC1</b>
999999H59M	6-30VDC	<b>LT8MD1</b>

**Power Supply:**  
2 x AA batteries included. Estimated Battery life is 3 years. Low battery indication.

**Connections:**

- BLUE INPUT 80-250VAC or 6-30VDC or Switch Contact
- WHITE RESET

For more hour meters see page 163

**ELECTROMECHANICAL TIMERS**

**Mechanical Timers**

Time Range	Code	Time Range	Code
2-30s	<b>G-100 30S</b>	1-15m	<b>MI-4 15M</b>
3-60s	<b>G-100 60S</b>	1.6-30m	<b>MI-4 30M</b>
15-300s	<b>G-100 300S</b>	3-60m	<b>MI-4 60M</b>
10-4m (240 sec)	<b>G-100 4M</b>	6-120m	<b>MI-4 120M</b>
20-7m (420 sec)	<b>G-100 7M</b>	15m-6h	<b>MI-4 6H</b>
45-15m	<b>G-100 15M</b>	30m-12h	<b>MI-4 12H</b>
1.5-30m	<b>G-100 30M</b>	1-24h	<b>MI-4 24H</b>
3-60m	<b>G-100 60M</b>		

Time tolerance  $\pm 3\%$   
Contact 16A @ 250VAC (NO + NC)

**With Motor**

Time Range	Code	Speed	No Reset	With Reset
0.3-12h	<b>JV100 12H*</b>	10Hz	<b>LC8MC1</b>	<b>LC8MC1R</b>
0.6-24h	<b>JV100 24H*</b>	50Hz	<b>LC8MC3</b>	<b>LC8MC3R</b>

\*Add AC voltage to code 110V, 230V, 400V  
More accurate for long time ranges. Time tolerance  $\pm 2\%$   
Contact 16A @ 250VAC (NO + NC)

8 digit LCD totalizer (up count) with external reset. Battery life 3 years type 'AA' 1.5V 2pcs (included). Low battery indication. Contact Input.

**Connections:**

- BLACK SWITCH CONTACT INPUT
- WHITE RESET

**TOTALIZER**

**LCD Totalizer - Battery Operated**

Size 56 x 31mm  
Panel cutout 50 x 25mm

**COUNTERS & TOTALIZERS**

Operation	4 Digit Up or Down Counter 0-9999	4 Digit Up or Down Counter 0-9999 with power off memory	3 Digit Up Counter 0-999	4 Digit Counter 6 Digit Totalizer	6 Digit Up or Down Counter
<b>Code</b>	<b>AH5K</b>	<b>SC-48</b>	<b>ASC-3</b>	<b>NC-4116</b>	<b>NC-611</b>
<b>Relay Outputs</b>	5A @ 250VAC	5A @ 250VAC	5A @ 250VAC	3A @ 250VAC	
<b>Size</b>	48 x 48mm Panel Mount & 8 PIN plug-in c/w mounting bracket	48 x 48mm Panel Mount & 8 PIN plug-in c/w mounting bracket	65 x 50mm Panel Mount & 8 PIN plug-in	72 x 72mm Panel Mount only	
<b>Specification</b>	Up/Down count to 9999 Auto Reset or Reset by removing power. 12VDC 30mA supply for proximity switches Input: Contact or NPN proximity sensor (see pages 208-229) 250CPS	Up/Down count to 9999 Sampling Multiplying Factor Auto Reset Manual Reset Output Relay Delay: 0.1 to 9.9 sec. 12VDC 30mA supply for proximity sensor (see pages 208-229) 500CPS	Up Count to 999 Contact Input. Reset by removing power 20CPS	6 digit pulse counter with delay auto reset, instant reset, auto/man. reset and self hold. Remote start/stop reset. Total reset on front of unit. Selectable 250CPS or 25CPS Addition/Subtraction Count. Output: Relay and NPN O/P	
<b>Supply Volts</b>	24-240VAC/DC	AC: 110 or 230VAC	AC: 110 and 230VAC	AC: 110 and 230VAC	

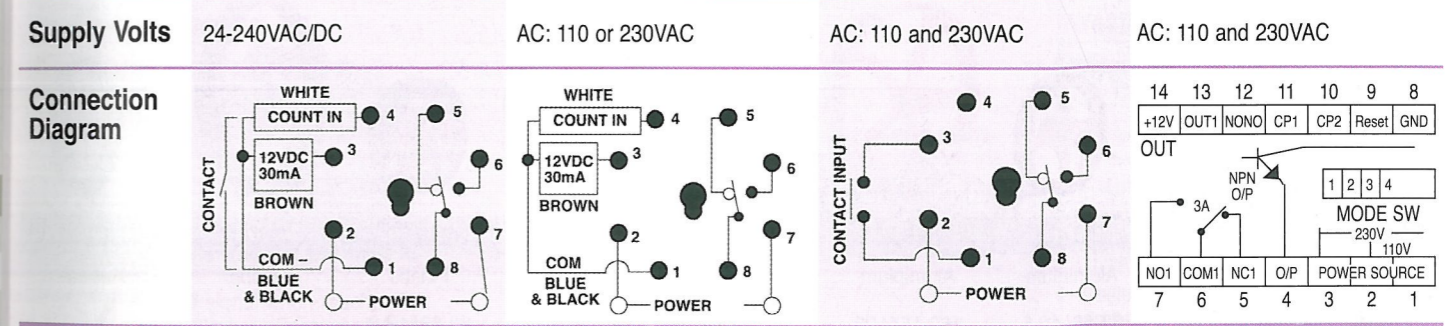

**Other Counters**

**Mechanical Pulse Counters 6 Digits (Panel Mount)**

**Totalizing Counter**

**Preselect Counter**

AC:	No Reset	With Reset	Code	Type	Code	Type
	<b>NX-06P</b> 24VAC	<b>E-16Y</b> 24VAC	<b>CC120/1*</b>	Namur, Negative edge trigger	<b>CC701*/NSP</b>	Namur DC (PNP/NPN)
	<b>NX-06P</b> 110VAC	<b>E-16Y</b> 110VAC	<b>CC120/2*</b>	Namur Positive edge trigger		
	<b>NX-06P</b> 230VAC	<b>E-16Y</b> 230VAC	<b>CC120/4*</b>	DC (NPN/PNP) Positive edge trigger		
	Count Speed 10CPS	Count Speed 10CPS				
	Panel cutout 25 x 40mm	Panel cutout 25 x 45mm				
<b>DC:</b>	<b>FX-06P</b> 12VDC	<b>E-16Y</b> 12VDC				
	<b>FX-06P</b> 24VDC	<b>E-16Y</b> 24VDC				
	Count Speed 20CPS	Count Speed 10CPS				
	Panel cutout 19 x 30mm	Panel cutout 25 x 45mm				

**Base Mount**

No Reset	Code	Type
	<b>LFC-6N</b>	12VDC
	<b>LFC-6N</b>	24VDC
		Count Speed 20CPS

On-time continuously rated at rated voltage

For detailed connection diagrams for different applications please contact our technical department

**NEW RANGE**

**METER COUNTER ASSEMBLIES**

**EMIT**



Code	EM-8MP	EM-12MP	EM-12MTP	EM-24MP
Digit Size	7mm	7mm	7mm	7mm
Max Speed	500mpm	300mpm	300mpm	200mpm
Reset	Pushbutton	Pushbutton	Pushbutton	Pushbutton
Weight	1.4kg	2.1kg	2.7kg	0.5kg
Diameters	-	3 to 23mm	3 to 23mm	3 to 23mm
Max Length	9999.99m	9999.99m	9999.99m	9999.99m
Wheel Size	500mm	500mm	500mm	200mm
Spare Counter	EM-12M	EM-12M	EM-12M	EM-24M

- Meter counter 12m
- 2 wheels 500mm
- Counterbalance
- Fabric measuring, steel rolls, etc.
- For measuring cables, pipes, ropes, etc.
- c/w bench clamp.
- For measuring cables, pipes, ropes, etc.
- Manual table assembly.
- For measuring cables, pipes, ropes, etc.
- Manual hand grip.

**Accessories**

**EMIT**

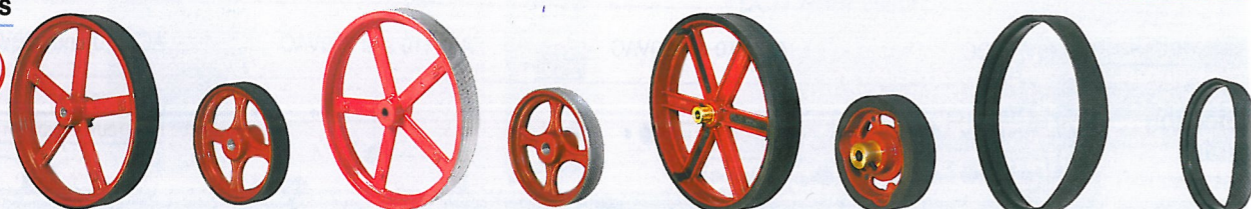

Code	EM-G5	EM-G2	EM-A5	EM-A2	EM-E5	EM-E2	RG500	RG200
Material	Aluminium	Aluminium	Aluminium	Aluminium	Plastic	Plastic	Rubber	Rubber
Diameter/ Thickness	159.154/ 25	63.66/ 12.5	159.154/ 28	63.66/ 13	159.154/ 24.5	63.66/ 17.6		
Perimeter	500mm (2:1)	200mm (5:1)	500mm (2:1)	200mm (5:1)	500mm (2:1)	200mm (5:1)	500mm	200mm
Axle	Ø7mm	Ø6mm	Ø7mm	Ø6mm	Ø7mm	Ø6mm		
Accessory for:	8MP 12MP 12MTP	24MP	8MP 12MP 12MTP	24MP	8MP 12MP 12MTP	24MP	EM-G5 EM-E5	EM-G5 EM-E5

**Tally Counters**



Code	H102	D102C
	4 Digit Counters Ideally used for traffic surveys, assembly line parts counting, attendance at any functions etc.	

**Road Counter**



Code	WM-12M	WM-08
	• 318mm (12") wheel • Accuracy 99.96% • Carry bag included • Telescopic handle • Kick Down Stand • Handle Reset	• 212mm (8") wheel • Accuracy 99.96% • Carry bag included • Telescopic handle • Reset

**NEW RANGE**

**MECHANICAL COUNTERS**

**EMIT**

**Meter Counters**

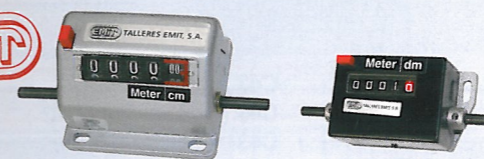

Code	EM-12M	EM-24M
Digits	5	5
Digit Size	7mm	4.5mm
Max Speed	500mpm	500mpm
Reset	Pushbutton	Pushbutton
Size	150 x 80 x 50.5mm	112 x 45 x 35mm

- Position of the impulse shaft on both sides.
- Addition/subtraction variable according to requirements.
- Turning relation:  
2 turns = 1m
- Turning relation:  
5 turns = 1m

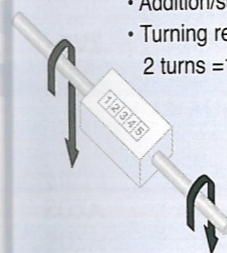

Please note: our range of meter and turn counters count as illustrated

**Turn Counters**



Code	EM-6R	EM-5R	EM-5RE
Digits	6	5	5
Digit Size	8mm	4.5mm	4.5mm
Max Speed	600rpm	500rpm	-
Reset	Key	Pushbutton	Knob
Size	150 x 80 x 50.5mm	112 x 45 x 35mm	62 x 45.5 x 30mm

- Position of the impulse shaft on both sides.
- Addition/subtraction variable according to requirements.
- Spare reset key.  
Code: **EM-ZSK**
- Position of the impulse shaft on both sides.
- Addition/ subtraction variable according to requirements.
- Special for use in adverse environments: Chemical industries, outdoors, etc.

**Pre-Select Counters**

**EMIT**



- Position of the impulse shaft on both sides.
- Addition/ subtraction variable according to requirements.
- Cuts the electrical signal when reaches "0" reducing from a number previously selected.
- 1 C/O 5A@230VAC

Code	EM-12EPR
Digits	5
Digit Size	7mm
Max Speed	-
Reset	Pushbutton
Size (mm)	150 x 80 x 55

**Revolution Counters**

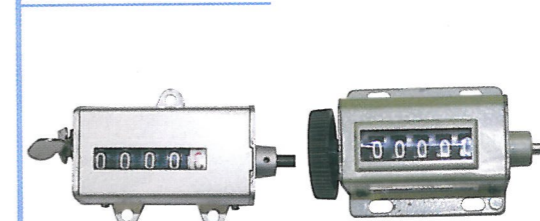

Code	EM-12EPR	JJ-75-I	JJ-67-1
Digits	5	5	5
Digit Size	7mm	8	4.4
Max Speed	-	350rpm	350rpm
Reset	Pushbutton	Lever	Wheel
Size (mm)	150 x 80 x 55	147 x 72 x 57	80 x 37 x 30

**Weatherproof Stroke Counter**



- Position of lever on the shaft, variable according to requirements.
- Rear mounting by ØM4 screws

**Stroke Counters**

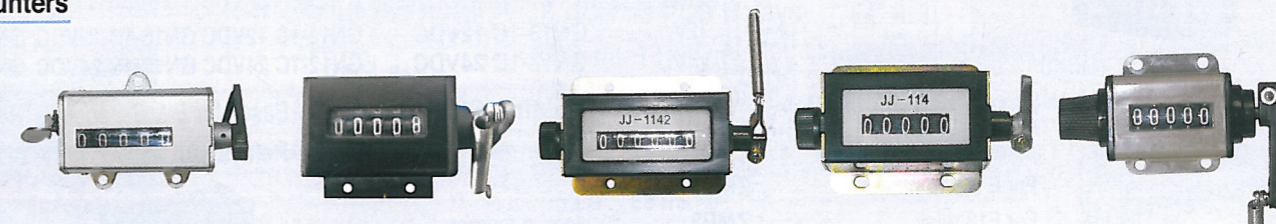

Code	JJ-75-II	JJ-108A	JJ-1142	JJ-114	JJ-101
Digits	5	5	6	5	5
Digit Size (mm)	8	4.4	4.4	4.4	4
Max Speed	500c/s	500c/s	500c/s	500c/s	500c/s
Reset	Lever	Non-Reset	Wheel	Wheel	Wheel
Size (mm)	119 x 72 x 57	50 x 42 x 35	86 x 47 x 34	80 x 46 x 32	65 x 37 x 32

Position of lever on shaft, variable according to requirements.  
Automatic return to initial position after each impulse.

**RELAYS & BASES**

**C - Series Relays - 10A 250V - c/w Flag and LED Indication**

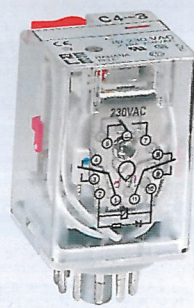

C43

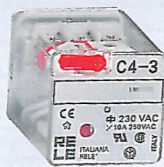

C42 8 Pin

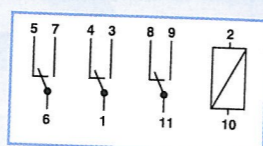

C43 11 Pin

8 Pin 2 C/O	11 Pin 3 C/O	AC	DC
C42	C43	6 VAC	6 VDC
C42	C43	12 VAC	12 VDC
C42	C43	24 VAC	24 VDC
C42	C43	32 VAC	32 VDC
C42	C43	36 VAC	36 VDC
C42	C43	48 VAC	48 VDC
C42	C43	60 VAC	60 VDC
C42	C43	110 VAC	110 VDC
C42	C43	230 VAC	220 VDC

**Bases for C42 & C43 Relays**

Description	Width	Code
<b>Bases for C42 and C43 relays</b>		
Screw terminal base (IP20 Protection) 300V		
8 PIN	40mm	ZOVI
11 PIN	43mm	ZUVI
Screw terminal oval base (IP20 Protection) 300V		
8 PIN (black)	38mm	BOV
11 PIN (black)	38mm	BUV
Screw terminal base (IP20 Protection) 400V		
8 PIN	38mm	ZVE8
11 PIN	38mm	ZVE11
Screw terminal base (IP00 Protection) 300V		
8 PIN	36mm	ZROV
11 PIN	36mm	ZRUV

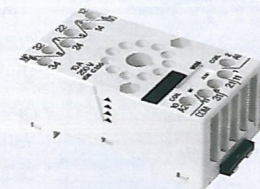

Description	Width	Code
Screw terminal base (IP20 Protection) 300V		
8 PIN	38mm	ZVO
11 PIN	38mm	ZVU
Suitable for LED module		
Solder panel base 300V		
8 PIN		AZOS
11 PIN		AZUS
Solder Cable cover base 300V		
8 PIN		ZOQS
11 PIN		ZUQS
Printed circuit base 300V		
8 PIN		AZOC
11 PIN		AZUC

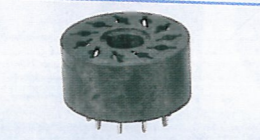
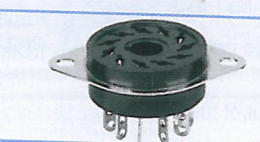

**Accessories**

Retaining clip for C42 & C43 relays	MBOU
Diode Module for ZVO & ZVU	A-D
LED Module for ZVO & ZVU	AL*

\*Add voltage 024, 060, 230 (110-230VAC/DC)

**G-series Low-profile hermetically sealed PCB Relays**

Volts DC	3.5mm Pin spacing		5mm Pin spacing		
	12A (1C/O)	12A (1C/O)	16A (1C/O)	8A (2C/O)	
12V	GN13-1C 12VDC	GN12-1C 12VDC	GN16-1C 12VDC	GN8-2C 12VDC	
24V	GN13-1C 24VDC	GN12-1C 24VDC	GN16-1C 24VDC	GN8-2C 24VDC	



GN12/13

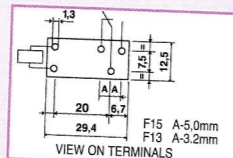

**Bases for E-Series Relays 10A 250V**

Description	Code
Screw terminal IP20 For E & F15 relays	ZME5
For F13 relay	ZME3

**LED Module** - Specify voltage: 024, 060, 110, 230VAC/DC  
Fits ZME3 and ZME5 bases only

Description	Code
Screw terminal IP20 For E relays	ZMEM/5

Description	Code
Screw terminal IP20 For E relays	ZMEP/5

**Bases for E & G-Series Relays 10A 250V**

Description	Code
Retaining Clip	MPE
Printed Circuit Base IP20 For GN13 relays 3.5mm pin spacing.	ZMECS/3.5

Description	Code
Printed Circuit Base IP20 For E & F15 relays 5.0mm pin spacing.	ZMECS/5

**RELAYS & BASES**

**D - Series Relays - c/w Flag Indication and Mechanical Latch**

1 C/O 16A	2 C/O 10A	4 C/O 5A	AC	DC
<b>Base Mounting</b>				
D1/N	D2/N	D4/N	6 VAC	6 VDC
-	D2/N	D4/N	12 VAC	12 VDC
-	D2/N	D4/N	24 VAC	24 VDC
-	D2/N	D4/N	48 VAC	48 VDC
-	D2/N	D4/N	60 VAC	60 VDC
D1/N	D2/N	D4/N	110 VAC	110 VDC
-	D2/N	D4/N	230 VAC	220 VDC

<b>PCB Mounting</b>				
-	D2/P	D4/P	-	12 VDC
D1/P	D2/P	D4/P	24 VAC	24 VDC
-	D2/P	D4/P	110 VAC	-
-	D2/P	D4/P	230 VAC	-

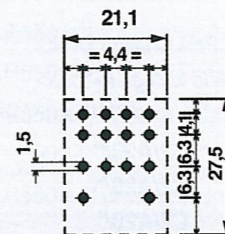
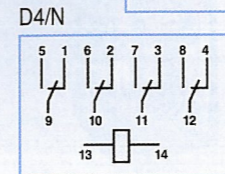
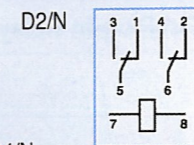

**Bases & Accessories for D series relays**

Description	Width	Code
Compact screw terminal base • IP20 • 250V • LED Modules		
For D1 & D2 Relays	26mm	ZMD2
For D4 Relays	26mm	ZMD4
Ejector/Retaining Clip		MPD
LED Module		ML*

\*Add Voltage: 24, 110, 230VAC/DC

Description	Width	Code
Screw terminal base • IP20 • 300V • LED Modules		
For D1 & D2 relays	30mm	ZM2VP
For D3 relays	30mm	ZM3VP†
For D4 relays	30mm	ZM4VP

†Does not accept LED module

LED Module for ZM2VP/ZM4VP/ZM4M AL\*

\*Add Voltage 024, 060, 230 (110-230VAC/DC)

Diode Module A-D

Screw terminal compact base  
• IP20 • 250V

Suitable for Diode or LED module

For D4 relays 26mm ZM4M

Description	Code
Printed circuit base 250V	
For D1 & D2 relays	ZM2CS
For D3 relays	ZM3CS
For D4 relays	ZM4CS
For D6 relays	ZM6CS
For D8 relays	ZM8CS

Description	Code
Solder panel base 250V	
For D1 & D2 relays	ZM2SP
For D3 relays	ZM3SP
For D4 relays	ZM4SP

**Retaining Clips**

D1 to D4 relays	MBD
For ZM4M base	MBM

**E - Series PCB Relays**

Standard Relays			Latching Bi-Stable Relays			Voltages	
2 C/O 5A	1 C/O 10A	1 C/O 16A	1 Coil 1 C/O 10A	1 Coil 2 C/O 5A	2 Coil 2 C/O 5A	AC	DC
E52/S	E51/S	-	-	-	-	-	4VDC
E52/S	E51/S	E61/S	-	-	-	6VAC	6VDC
E52/S	E51/S	E61/S	-	-	-	-	9VDC
E52/S	E51/S	E61/S	E51/R1	E52/R1	E52/R2	12VAC	12VDC
E52/S	E51/S	E61/S	E51/R1	E52/R1	E52/R2	24VAC	24VDC
E52/S	E51/S	E61/S	-	-	-	36VAC	36VDC
E52/S	E51/S	E61/S	-	-	-	48VAC	48VDC
E52/S	E51/S	E61/S	-	-	-	60VAC	60VDC
E52/S	E51/S	E61/S	-	-	-	110VAC	110VDC
E52/S	E51/S	E61/S	E51/R1	E52/R1	-	230VAC	-

**Wiring for Latching Relays**

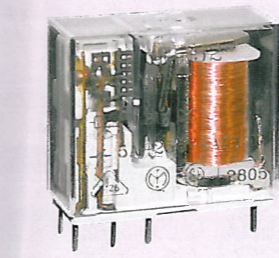
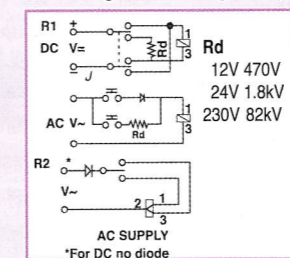

E52/S 5A

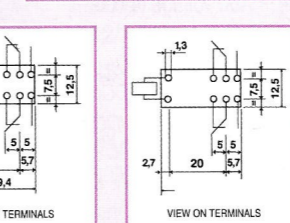

E52/R2 5A

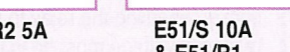

E51/S 10A & E51/R1

INDUSTRIAL RELAYS

Type	8 Pin Plug-in Relay	11 Pin Plug-in Relay	8 Pin Plug-in Relay	11 Pin Plug-in Relay
UL recognised, CE approval				
Colour coding: Orange: AC Blue: DC				
Contact Rating: 10A				
Relay type	2 Pole Change Over	3 Pole Change Over	2 Pole Change Over	3 Pole Change Over
*AC	*DC	*Add voltage to code	*Add voltage to code	*Add voltage to code
240VAC	—	R6002-*L	R6003-*L	—
230VAC	220VDC	R6002-*L	R6003-*L	—
110VAC	110VDC	R6002-*L	R6003-*L	—
48VAC	48VDC	R6002-0*L	R6003-0*L	—
36VAC	36VDC	R6002-0*L	R6003-0*L	—
32VAC	32VDC	R6002-0*L	R6003-0*L	—
24VAC	24VDC	R6002-0*L	R6003-0*L	—
12VAC	12VDC	R6002-0*L	R6003-0*L	—
6VAC	6VDC	R6002-00*L	R6003-00*L	—
Features	Test button function Flag plus LED	Test button function Flag plus LED	Test button function & Flag ind	Test button function & Flag ind
Wiring Diagram				

**Bases for R6002 and R6003 Relays**  
Screw Terminals IP20

Code	Description
BOV-B	8 Pin oval base blue
BUV-B	11 Pin oval base blue
RB750-08R	8 Pin rectangle base blue
RB740-11R	11 Pin rectangle base blue

Screw Terminals IP20

RB083-08R	8 Pin rectangle base blue
RB113-11R	11 Pin rectangle base blue

**Bases for C2/A20 and C3/A30 IP20**

S2-B	8 Pin rectangle base
S3-B	11 Pin rectangle base

Unique retainer clip securing module to socket providing protection against vibration.

**A - Series Relays**

	1 N/O	2 N/O	1 C/O	Coil Volts	
	30A	16A	16A	AC	DC
30A 1C/O	A1/1	A1/2	A1/A	12 VAC	12 VDC
16A 2C/O	A1/1	A1/2	A1/A	24 VAC	24 VDC
	A1/1	A1/2	A1/A	110 VAC	
	A1/1	A1/2	A1/A	230 VAC	

For use with fast-on connectors

**Timers**

Code	Description
CT2A*	8 Pin Delay OFF timer
CT3A*	11 Pin Delay OFF timer
CT2B*	8 Pin Equal Repeating timer
CT3B*	11 Pin Equal Repeating timer
CT2E*	8 Pin Delay ON timer
CT3E*	11 Pin Delay ON timer
CT2K*	8 Pin one-shot pulse start timer
CT3K*	11 Pin one-shot pulse start timer
CT2W*	8 Pin one-shot timer
CT3W*	11 Pin one-shot timer

\*Add voltage to code:  
S (9.5-18VDC),  
L (20-65VAC/DC),  
M (90-150VAC/DC for timer A & K),  
U (180-265VAC/DC for timer A & K),  
L (90-265VAC/DC for timer B, E & W)

The module CT2 & CT3 are electronic timers which are designed to be inserted between a standard plug-in relay and socket, enabling the relay to be operated as a timer relay. The relay coil voltage must be in the range shown for each model.

INDUSTRIAL RELAYS

Type	8 Pin Plug-in Relay Flat	14 Pin Plug-in Relay Flat	8 Pin Plug-in Relay Flat	14 Pin Plug-in Relay Flat
RELAYS - Test button function - Flag plus LED - Orange for AC - Blue for DC Contact Rating: 10A				
Relay Type	2 Pole Change Over	4 Pole Change Over	2 Pole Change Over	4 Pole Change Over
*AC	*DC	*Add voltage to code	*Add voltage to code	*Add voltage to code
230VAC	—	R5502-*L	R5504-*L	R5602-*L
110VAC	110VDC	R5502-*L	R5504-*L	R5602-*L
48VAC	48VDC	R5502-0*L	R5504-0*L	R5602-0*L
24VAC	24VDC	R5502-0*L	R5504-0*L	R5602-0*L
12VAC	12VDC	R5502-0*L	R5504-0*L	R5602-0*L
Wiring Diagram				

**Bases for R5502 and R5504 Relays**  
Screw Terminal Base IP20

Code	Description
RB943-08F	8 Pin blue base for 2 pole relays
RB944-14F	14 Pin blue base for 2 & 4 pole relays

**Bases for R5602 and R5604 Relays**  
Screw Terminal Base IP20

Code	Description
ZM6V	Base for R5602
ZM8V	Base for R5604

ZM3VP 11 Pin black base for 2 & 3 pole relays

**AB - Series Relays 16A**

2 C/O	3 C/O	Volts	
16A	16A	AC	DC
AB2	AB3	12 VAC	12 VDC
AB2	AB3	24 VAC	24 VDC
AB2	—	48 VAC	48 VDC
AB2	AB3	110 VAC	110 VDC
AB2	AB3	230 VAC	—

**Bases for AB2 and AB3 Relays**  
Screw Terminal Base IP20

Code	Description
ZAV/A	Base for AB2 relay
ZACS	P.C.B. base for AB2 relay

**Interface Relays**

Code	Description
C10/A10*	1 c/o 10A relay, plug-in type
C12/A21*	2 c/o 5A relay, plug-in type
CSS-AZ	Solid-state relay, Input 5-32VAC Out switch 3A 250VAC

\*Add coil voltage to code: 230VAC, 110VAC, 24VDC, 12VDC

**Bases for Interface Relays**

Code	Description
S-12	Base for C12 relay
S-10M	Base for C10/ C14 relay

**RELAYS**

**RELAY INTERFACE MODULES**

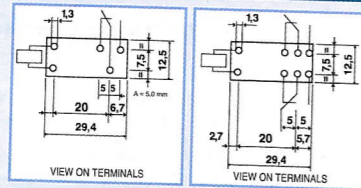
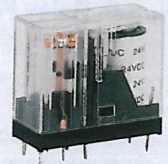

**JQX - Series PCB Relays**

Voltage	1C/O 10A	2C/O 5A	1C/O 16A
12VDC	JQX-14FC-1C 12VD	JQX-14FC-2C 12VD	JQX-14FC-1CH 12
24VDC	JQX-14FC-1C 24VD	JQX-14FC-2C 24VD	JQX-14FC-1CH 24

**Base 10A 250V for JQX Relay IP20**

Code	Description
PSF14AE/L	For E relays 5mm PIN spacing

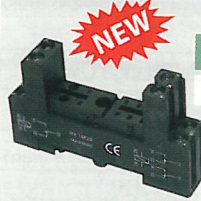

**JQX-50F Series**

1 C/O 30A  
No Base, screw terminals

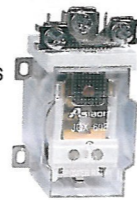

**30A 1C/O**

Code	Volts
JQX-50F	12 VDC
JQX-50F	24 VDC
JQX-50F	110VAC
JQX-50F	230VAC

**T73 - Series Relays 10A 1C/O**

1 C/O 10A @ 250VAC

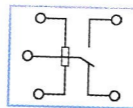

T73 12VDC	12 VDC
T73 24VDC	24 VDC

**F - Series Automotive Relays**

1 C/O 30A Open type

1 C/O 40A Enclosed type

F1/C 12VDC	12 VDC
F1/C 24VDC	24 VDC
F2 12VDC	12 VDC
F2 24VDC	24 VDC

**TRK Series Automotive Relays 30A, 80A 1C/O**

1 C/O 30A

1 C/O 80A

TRK792 12VDC	12 VDC
TRK792 24VDC	24 VDC
ALB-80 12VDC	12VDC
ALB-80 24VDC	24VDC

**CGB & JQX-30F Series**

40A 1C/O 20A 2C/O

CGB-1C	JQX-30F	12 VDC
CGB-1C	JQX-30F	24 VDC
CGB-1C	JQX-30F	110VAC
CGB-1C	JQX-30F	230VAC

**RE1**

**DIN MOUNT RELAYS**

**DIN Mount Relays • 16A - 250V ~**

• Capacity: incandescent lamps 2400W  
fluorescent lamps with p.f. correction 500W  
halogen lamps 1000W

Momentary Relay Code	Contacts Type	DIN Width (17.5mm)	Control voltage VAC	Step Relay Code	Contacts Type
SH99132	N/O	1	12V	GW96626	C/O
GW96602	N/O	1	24V	SH99063	C/O
SH99138	N/O	1	230V	GW96628	C/O
GW96613	change-over	1	230V	SH99038	2 N/O
SH99232	4 N/O	2	12V	GW96641	4 N/O
GW96617	4 N/O	2	24V	SH99093	4 N/O
GW96618	4 N/O	2	230V	SH99098	4 N/O

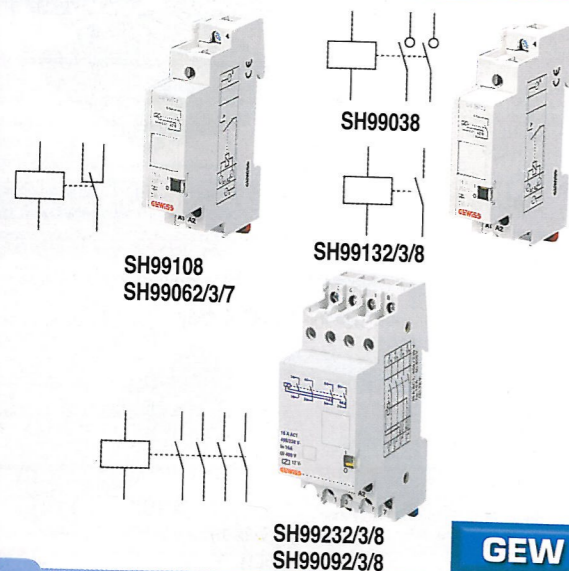

**GEW**

**Open Base Type**

**Closed Base**

**Slim Type 5A**

**Box Type**



IMZ  
DIN Mounting

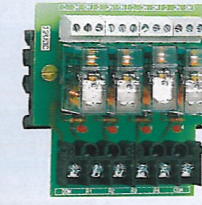

RB-4/8/12L  
Fixed Relays

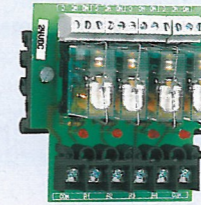

RB-4/8/12LP & LPP  
Plug-in Relays



RB-1CP  
RB2-1CP

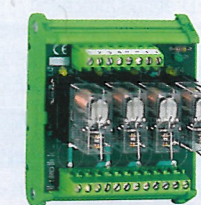

RB-4/8/12CP



RB-1SL

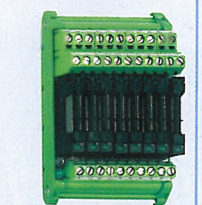

RB-8SL



RB-4/8/16BT

	1-Way	4-Way	8-Way	12-Way	16-Way
<b>SPDT (1C/O) 10A (DIN Mounting)</b>					L & LP with 20 way ribbon plug
Fixed relays open base	-	RB-4L*	RB-8L*	RB-12L*	RB-16L*
Plug-in relays open base	-	RB-4LP*	RB-8LP*	RB-12LP*	RB-16LP*
Plug-in relays closed base	RB-1CP*	RB-4CP*	RB-8CP*	RB-12CP*	RB-16CP*
Slim type	RB-1SL*	-	RB-8SL 24VDC	-	-
Box type	-	RB-4BT 24VDC	RB-8BT 24VDC	-	RB-16BT 24VDC
Base without relay	IMZ	-	-	-	-

\*Add voltage required: 24, 110, 230VAC; 12, 24, 110VDC

\*NB: All Codes are for common negative, for common positive add "P" to Code, eg. RB-4LPP  
Common Positive only available in LP Range

**DPDT (2 C/O) 5A (DIN Mounting)**

Fixed relays open base	-	RB2-4L*	RB2-8L*	RB2-12L*	RB2-16L*
Plug-in relays open base	-	RB2-4LP*	RB2-8LP*	RB2-12LP*	RB2-16LP*
Plug-in relays closed base	RB2-1CP*	RB2-4CP*	RB2-8CP*	RB2-12CP*	RB2-16CP*

\*Add voltage required: 24, 110, 230VAC; 12, 24, 110VDC

\*NB: All Codes are for common negative, for common positive add "P" to Code, eg. RB2-4LPP  
Common negative only available in LP Range

**Inter-Connecting Modules**

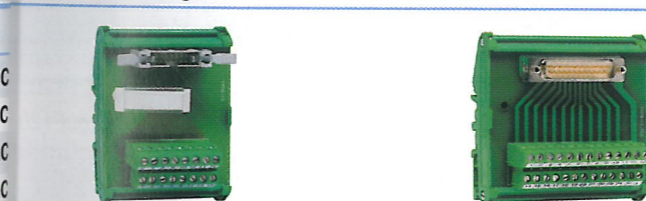

Flat Connector

Sub-D Connector Male

Code	No. of Poles	Code	No. of Poles
JUM72-16	16-Way	JUM72-D15	15-Way
JUM72-26	26-Way	JUM72-D25	25-Way
JUM72-34	34-Way	JUM72-D37	37-Way
JUM72-40	40-Way	JUM72-D50	50-Way
JUM72-50	50-Way		

**Opto Coupling Modules**

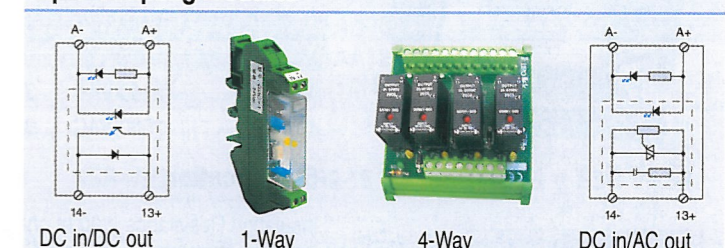

Code 1-Way	Code 4-Way	Input Volts	Output Volts	Output Current
OCM1-24VDC	OCM4-24VDC	24VDC	5-48VDC	3A
OCM1-240VAC	OCM4-240VAC	240VAC	240VAC	2A
ET-MS01	ET-MSZ04	24VDC	240VAC	4A

**Slim Type Relays**

Code	Volts	Description
SA-1A	12VDC	5A C/O
SA-1A	24VDC	5A C/O

Size:  
20mm(L) x 5mm(W) x 12.5mm(H)

**Step Relay (Base Mount) 10A @ 250VAC**

Code	No. of Step	1	2	3	4
AFH-BF01*	2				
AFH-BF02*	2				
AFH-BF04*	4				

\*Add Voltage: 12VDC, 12VAC, 24VDC, 24VAC, 110VAC, 230VAC  
NB: Not continuously rated coils (pulse only)